

Administration Guide for NetWare 6.5 SP5/SP6

Novell® Business Continuity Clustering

1.1 SP1

September 21, 2010

www.novell.com



Legal Notices

Novell, Inc., makes no representations or warranties with respect to the contents or use of this documentation, and specifically disclaims any express or implied warranties of merchantability or fitness for any particular purpose. Further, Novell, Inc., reserves the right to revise this publication and to make changes to its content, at any time, without obligation to notify any person or entity of such revisions or changes.

Further, Novell, Inc., makes no representations or warranties with respect to any software, and specifically disclaims any express or implied warranties of merchantability or fitness for any particular purpose. Further, Novell, Inc., reserves the right to make changes to any and all parts of Novell software, at any time, without any obligation to notify any person or entity of such changes.

Any products or technical information provided under this Agreement may be subject to U.S. export controls and the trade laws of other countries. You agree to comply with all export control regulations and to obtain any required licenses or classification to export, re-export or import deliverables. You agree not to export or re-export to entities on the current U.S. export exclusion lists or to any embargoed or terrorist countries as specified in the U.S. export laws. You agree to not use deliverables for prohibited nuclear, missile, or chemical biological weaponry end uses. See the [Novell International Trade Services Web page \(http://www.novell.com/info/exports/\)](http://www.novell.com/info/exports/) for more information on exporting Novell software. Novell assumes no responsibility for your failure to obtain any necessary export approvals.

Copyright © 2007-2010 Novell, Inc. All rights reserved. No part of this publication may be reproduced, photocopied, stored on a retrieval system, or transmitted without the express written consent of the publisher.

Novell, Inc., has intellectual property rights relating to technology embodied in the product that is described in this document. In particular, and without limitation, these intellectual property rights may include one or more of the U.S. patents listed on the [Novell Legal Patents Web page \(http://www.novell.com/company/legal/patents/\)](http://www.novell.com/company/legal/patents/) and one or more additional patents or pending patent applications in the U.S. and in other countries.

Novell, Inc.
404 Wyman Street, Suite 500
Waltham, MA 02451
U.S.A.
www.novell.com

Online Documentation: To access the latest online documentation for this and other Novell products, see the [Novell Documentation Web page \(http://www.novell.com/documentation/\)](http://www.novell.com/documentation/).

Novell Trademarks

For Novell Trademarks, see the [Novell Trademark and Service Mark list \(http://www.novell.com/company/legal/trademarks/tmlist.html\)](http://www.novell.com/company/legal/trademarks/tmlist.html).

Third-Party Materials

All third-party trademarks are the property of their respective owners.

Contents

About This Guide	7
1 Overview	9
1.1 Disaster Recovery Implications	9
1.2 Disaster Recovery Implementations	10
1.2.1 Stretch Clusters vs. Cluster of Clusters	10
1.2.2 Novell Business Continuity Clusters	13
1.2.3 Usage Scenarios	14
2 Installation and Setup	17
2.1 Requirements	17
2.1.1 Business Continuity Clustering Licensing	17
2.1.2 NetWare 6.5 SP5 or SP6 (OES 1 SP2 NetWare)	18
2.1.3 Novell eDirectory 8.8	18
2.1.4 Novell Cluster Services 1.8.2 for NetWare	19
2.1.5 Novell iManager	19
2.1.6 Identity Manager	20
2.1.7 Windows Workstation	21
2.1.8 OpenSLP	21
2.1.9 OpenWBEM	21
2.1.10 BASH	21
2.1.11 LIBC	21
2.1.12 autoexec.ncf File	21
2.1.13 Shared Disk Systems	21
2.1.14 Link Speeds	21
2.2 Installing Novell Business Continuity Clustering Software	22
2.2.1 Business Continuity Cluster Component Locations	22
2.2.2 Downloading the Business Continuity Clustering Software	23
2.2.3 Configuring a BCC Administrator User	24
2.2.4 Installing the Business Continuity Clustering Engine	27
2.2.5 Installing the Identity Manager Templates for Business Continuity Clustering	28
2.3 Configuring File System Mirroring	29
2.3.1 Configuring NSS Mirroring	30
2.3.2 Configuring SAN-Based Mirroring	33
2.3.3 LUN Masking	33
2.4 Setting Up Novell Business Continuity Clustering Software	33
2.4.1 Configuring Identity Manager Drivers for the Business Continuity Cluster	33
2.4.2 Configuring Clusters for Business Continuity	38
2.4.3 Configuring Cluster Resources for Business Continuity	43
2.5 Managing a Novell Business Continuity Cluster	46
2.5.1 Migrating a Cluster Resource to Another Cluster	46
2.5.2 Changing Cluster Peer Credentials	48
2.5.3 Viewing the Current Status of a Business Continuity Cluster	48
2.5.4 Generating a Cluster Report	49
2.5.5 Disabling Business Continuity Cluster Resources	49
2.5.6 Business Continuity Cluster Console Commands	50
2.6 Business Continuity Cluster Failure Types	52
2.6.1 SAN-based Mirroring Failure Types and Responses	53
2.6.2 Host-Based Mirroring Failure Types and Responses	54

3	Upgrading Business Continuity Clustering for NetWare	57
3.1	Upgrading Business Continuity Clustering from 1.0 to 1.1 for NetWare	57
3.1.1	Upgrading NetWare	57
3.1.2	Installing or Upgrading Identity Manager	58
3.1.3	Installing Business Continuity Clustering 1.1	58
3.1.4	Resetting BCC Administrator User Credentials	58
3.1.5	Authorizing the BCC Administrator User	58
3.1.6	Verifying SAN Scripts	59
3.1.7	Deleting and Re-Creating the BCC-Specific Identity Manager Drivers	59
3.2	Upgrading Business Continuity Clustering from 1.0 or 1.1 for NetWare to 1.1 for Linux	59
4	Troubleshooting Business Continuity Clustering 1.1	61
4.1	Cluster Connection States	62
4.2	Driver Ports	63
4.3	Excluded Users	64
4.4	Security Equivalent User	64
4.5	Certificates	65
4.6	Clusters Cannot Communicate	66
4.7	BCC Startup Flags	66
4.7.1	Using BCC Startup Flags on NetWare	66
4.7.2	Using BCC Startup Flags on Linux	67
4.8	Problems With BCC Installation on NetWare	67
4.9	Identity Manager Drivers for Cluster Synchronization Do Not Start	67
4.10	Identity Manager Drivers Do Not Synchronize Objects from One Cluster to Another	68
4.11	Tracing Identity Manager Communications	68
4.12	Peer Cluster Communication Not Working	69
4.13	Administration of Peer Clusters Not Functional	69
4.14	Resource Does Not Migrate to Another Cluster	70
4.15	Resource Cannot Be Brought Online	70
4.16	Dumping Syslog on NetWare	70
4.17	Slow Failovers	70
4.18	Resource Script Search and Replace Functions Do Not Work	71
4.19	Virtual NCP Server IP Addresses Won't Change	71
4.20	IP Address, Virtual Server DN, or Pool Name Does Not Appear on the iManager Cluster Configuration Page	71
4.21	Blank Error String iManager Error Appears While Bringing a Resource Online	72
4.22	Best Practices	72
4.23	Mapping Drives in Login Scripts	73
4.24	Mapping Drives to Home Directories by Using the %HOME_DIRECTORY Variable	73
4.25	BCC Error Codes	74
5	Virtual IP Addresses	77
5.1	Virtual IP Address Definitions and Characteristics	77
5.1.1	Definitions	77
5.1.2	Characteristics	78
5.2	Virtual IP Address Benefits	78
5.2.1	High Availability	78
5.2.2	Unlimited Mobility	81
5.3	Other Added Features	81
5.3.1	Support for Host Mask	81
5.3.2	Source Address Selection for Outbound Connections	81

5.4	Reducing the Consumption of Additional IP Addresses	82
5.5	Configuring Virtual IP Addresses	83
5.5.1	Displaying Bound Virtual IP Addresses	84
A	Implementing a Multiple-Tree BCC	85
A.1	Using Identity Manager to Copy User Objects to Another eDirectory Tree	85
A.2	Configuring User Object Synchronization	85
A.3	Creating SSL Certificates	86
A.4	Synchronizing the BCC-specific Identity Manager Drivers	87
A.5	Preventing Identity Manager Synchronization Loops	87
A.6	Migrating Resources to Another Cluster	89
B	Setting Up Auto-Failover	91
B.1	Enabling Auto-Failover	91
B.2	Creating an Auto-Failover Policy	92
B.3	Refining the Auto-Failover Policy	92
B.4	Adding or Editing Monitor Configurations	93
C	Security Considerations	95
C.1	Security Features	95
C.2	Security Configuration	95
C.2.1	BCC Configuration Settings	96
C.2.2	Security Information for Other Products	99
C.3	Other Security Considerations	100
D	Documentation Updates	101
D.1	April 30, 2008	101
D.1.1	Setting Up Novell Business Continuity Clustering Software	101
D.2	February 15, 2008	102
D.2.1	Installation and Setup	102
D.2.2	Troubleshooting Business Continuity Clustering 1.1	102

About This Guide

This guide describes how to install, configure, and manage Novell® Business Continuity Clustering 1.1 Support Pack 1 for NetWare® 6.5 Support Pack 5 or 6 (same as Novell Open Enterprise Server 1 Support Pack 2 for NetWare) in combination with Novell Cluster Services 1.8.2 for NetWare clusters.

- ♦ Chapter 1, “Overview,” on page 9
- ♦ Chapter 2, “Installation and Setup,” on page 17
- ♦ Chapter 3, “Upgrading Business Continuity Clustering for NetWare,” on page 57
- ♦ Chapter 4, “Troubleshooting Business Continuity Clustering 1.1,” on page 61
- ♦ Chapter 5, “Virtual IP Addresses,” on page 77
- ♦ Appendix A, “Implementing a Multiple-Tree BCC,” on page 85
- ♦ Appendix B, “Setting Up Auto-Failover,” on page 91
- ♦ Appendix C, “Security Considerations,” on page 95
- ♦ Appendix D, “Documentation Updates,” on page 101

Audience

This guide is intended for anyone involved in installing, configuring, and managing Novell Cluster Services™ for NetWare in combination with Novell Business Continuity Clustering for NetWare.

Feedback

We want to hear your comments and suggestions about this manual and the other documentation included with this product. Please use the User Comments feature at the bottom of each page of the online documentation, or go to www.novell.com/documentation/feedback.html and enter your comments there.

Documentation Updates

The latest version of this *Novell Business Continuity Clustering 1.1 for NetWare Administration Guide* is available on the [Business Continuity Clustering 1.1 Documentation Web site \(http://www.novell.com/documentation/bcc11/\)](http://www.novell.com/documentation/bcc11/).

Additional Documentation

For information about using Novell Business Continuity Clustering 1.1 for Linux, see the *Novell Business Continuity Clustering 1.1 Administration Guide for Linux*.

For information about using Novell Cluster Services for NetWare, see the *NW6.5 SP8: Novell Cluster Services 1.8.5 Administration Guide*.

For the latest information about Novell Identity Manager 2.0 or later, see the [Identity Management Documentation Web site \(http://www.novell.com/documentation/idm/\)](http://www.novell.com/documentation/idm/).

For the latest information about NetWare 6.5 SP5 or SP6, see the [OES 1 SP2 Documentation Web site \(http://www.novell.com/documentation/oes/\)](http://www.novell.com/documentation/oes/).

As corporations become more international, fueled in part by the reach of the World Wide Web, the requirement for service availability has increased. Novell® Cluster Services™ offers corporations the ability to maintain 24x7x365 data and application services to their users while still being able to perform maintenance and upgrades on their systems.

In the past few years, natural disasters (ice storms, earthquakes, hurricanes, tornadoes, and fires) have caused unplanned outages of entire data centers. In addition, US federal agencies have realized the disastrous effects that terrorist attacks could have on the US economy when corporations lose their data and the ability to perform critical business practices. This has resulted in initial recommendations for corporations to build mirrored or replicated data centers that are geographically separated by 300 km or more (the minimum acceptable distance being 200 km).

Many companies have built and deployed geographically mirrored data centers. The problem is that setting up and maintaining the two or more centers is a manual process that takes a great deal of planning and synchronizing. Even configuration changes must be carefully planned and replicated. One mistake and the redundant site is no longer able to effectively take over in the event of a disaster.

- ◆ [Section 1.1, “Disaster Recovery Implications,” on page 9](#)
- ◆ [Section 1.2, “Disaster Recovery Implementations,” on page 10](#)

1.1 Disaster Recovery Implications

The implications of disaster recovery are directly tied to your data. Is your data mission critical? In many instances, critical systems and data drive the business. If these services stop, the business stops. When calculating the cost of downtime, some things to consider are

- ◆ File transfers and file storage
- ◆ E-mail, calendaring and collaboration
- ◆ Web hosting
- ◆ Critical databases
- ◆ Productivity
- ◆ Reputation

Continuous availability of critical business systems is no longer a luxury, it is a competitive business requirement. The Gartner Group estimates that 40% of enterprises that experience a disaster will go out of business in five years and only 15% of enterprises have a full-fledged business continuity plan that goes beyond core technology and infrastructure.

1.2 Disaster Recovery Implementations

There are two main Novell Cluster Services implementations that you can use to achieve your desired level of disaster recovery. These include a stretch cluster and a cluster of clusters. The Novell Business Continuity Clustering product automates some of the configuration and processes used in a cluster of clusters.

- ♦ [Section 1.2.1, “Stretch Clusters vs. Cluster of Clusters,”](#) on page 10
- ♦ [Section 1.2.2, “Novell Business Continuity Clusters,”](#) on page 13
- ♦ [Section 1.2.3, “Usage Scenarios,”](#) on page 14

1.2.1 Stretch Clusters vs. Cluster of Clusters

- ♦ [“Stretch Clusters”](#) on page 10
- ♦ [“Cluster of Clusters”](#) on page 11
- ♦ [“Implementation Comparison”](#) on page 12

Stretch Clusters

A stretch cluster consists of one cluster in which the nodes in the cluster are located in geographically separate areas. All nodes in the cluster must be in the same eDirectory™ tree. In this architecture, the data is mirrored between two data centers that are geographically separated. All the machines in both data centers are part of one cluster, so that if a disaster occurs in one data center, the other automatically takes over.

Figure 1-1 Stretch Cluster

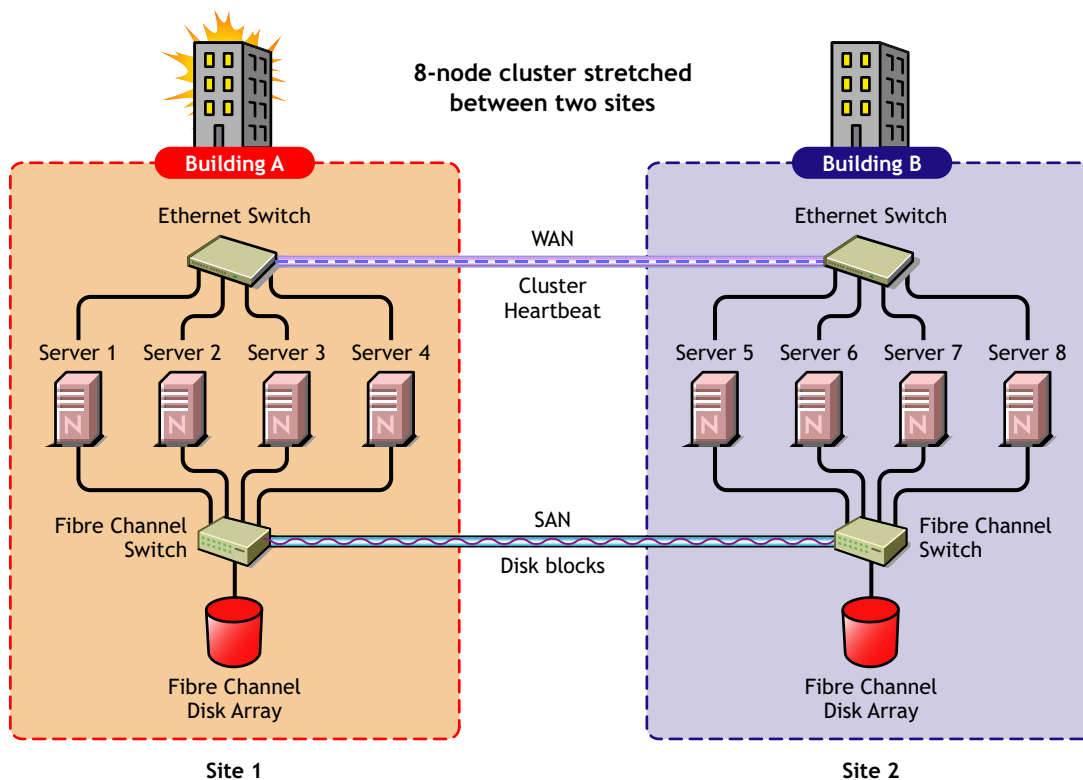

Cluster of Clusters

A cluster of clusters consists of two or more clusters in which each cluster is located in a geographically separate area. A cluster of clusters provides the ability to fail over selected cluster resources or all cluster resources from one cluster to another cluster. Typically, replication of data blocks between SANs is performed by SAN hardware, but it can be done by host-based mirroring for synchronous replication over short distances.

Figure 1-2 Cluster of Clusters

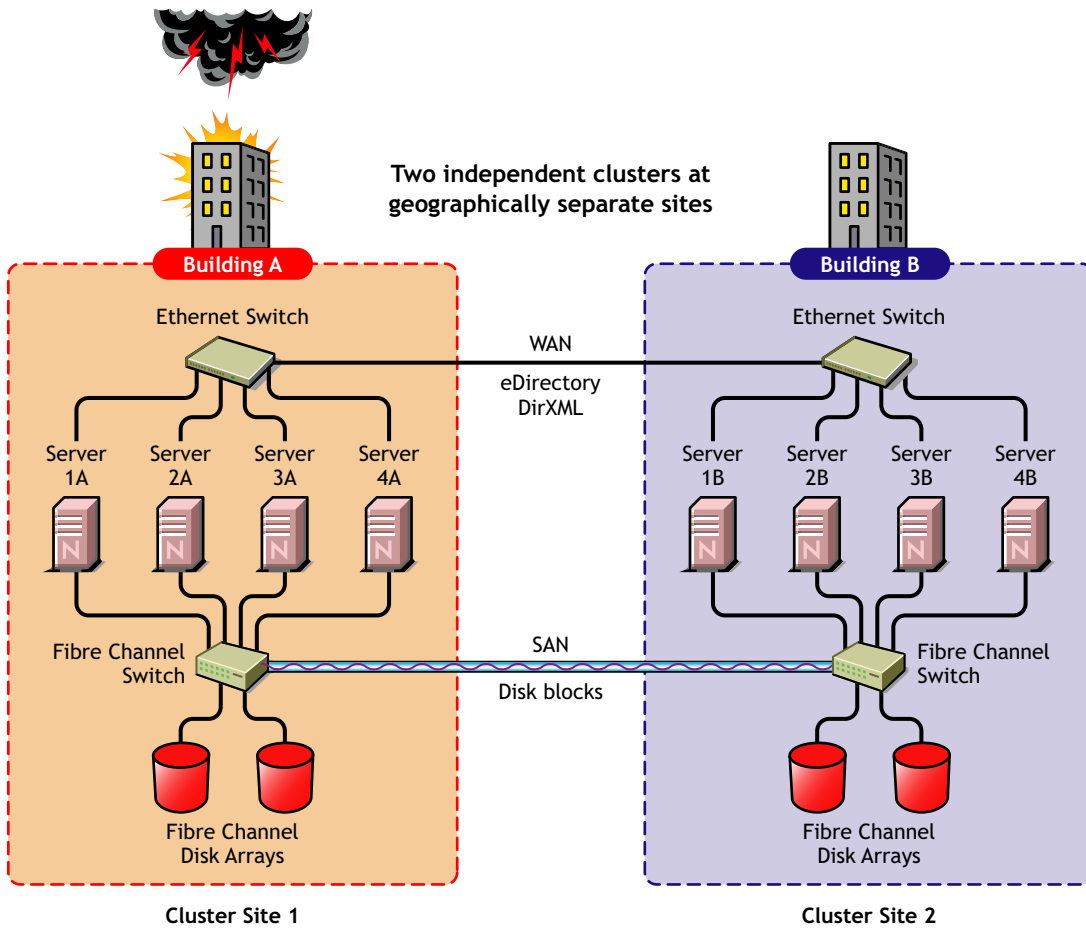

Implementation Comparison

Table 1-1 *Disaster Recovery Implementation Comparison*

	Stretch Cluster	Cluster of Clusters
Advantages	<ul style="list-style-type: none"> ◆ It automatically fails over. ◆ It is easier to manage than separate clusters. 	<ul style="list-style-type: none"> ◆ The chance of LUNs at both locations becoming primary is minimized. ◆ eDirectory partitions don't need to span the cluster. ◆ Each cluster can be in a separate eDirectory tree. ◆ IP addresses for each cluster can be on different IP subnets. ◆ It accommodates more than two sites, and cluster resources can fail over to separate clusters (multiple-site fan-out failover support). ◆ SBD partitions are not mirrored between sites.
Disadvantages	<ul style="list-style-type: none"> ◆ Failure of site interconnect can result in LUNs becoming primary at both locations (split brain problem) if host-based mirroring is used. ◆ An SBD partition must be mirrored between sites. ◆ It accommodates only two sites. ◆ All IP addresses must reside in the same subnet. ◆ The eDirectory partition must span the cluster. 	<ul style="list-style-type: none"> ◆ Resource configurations must be kept in sync manually.

	Stretch Cluster	Cluster of Clusters
Other Considerations	<ul style="list-style-type: none"> ◆ Host-based mirroring is required to mirror the SBD partition between sites. ◆ Link variations can cause false failovers. ◆ You could consider partitioning the eDirectory tree to place the cluster container in a partition separate from the rest of the tree. ◆ The cluster heartbeat must be increased to accommodate link latency between sites. You can set this as high as 30 seconds, monitor cluster heartbeat statistics, and then tune down as needed. ◆ Because all IP addresses in the cluster must be on the same subnet, you must ensure that your routers handle gratuitous ARP. Contact your router vendor or consult your router documentation for more information. 	<ul style="list-style-type: none"> ◆ Depending on the platform used, storage arrays must be controllable by scripts that run on NetWare® or Linux if the SANs are not SMI-S compliant.

1.2.2 Novell Business Continuity Clusters

Novell Business Continuity Clusters is a cluster of clusters similar to what is described above, except that the cluster configuration, maintenance, and synchronization have been automated by adding specialized software.

Novell Business Continuity Clustering software is an integrated set of tools to automate the setup and maintenance of a Business Continuity infrastructure. Unlike competitive solutions that attempt to build stretch clusters, Novell Business Continuity Clustering utilizes a cluster of clusters. Each site has its own independent clusters, and the clusters in each of the geographically separate sites are each treated as “nodes” in a larger cluster, allowing a whole site to do fan-out failover to other multiple sites. Although this can currently be done manually with a cluster of clusters, Novell Business Continuity Clustering automates the system by using eDirectory and policy-based management of the resources and storage systems.

Novell Business Continuity Clustering software provides the following advantages:

- ◆ Integrates with SAN hardware devices to automate the failover process using standards based mechanisms such as SMI-S.
- ◆ Utilizes Novell Identity Manager technology to automatically synchronize and transfer cluster-related eDirectory objects from one cluster to another.
- ◆ Provides the capability to fail over as few as one cluster resource, or as many as all cluster resources.

- ♦ Includes intelligent failover that lets you do site failover testing as a standard practice.
- ♦ Provides scripting capability for enhanced control and customization.
- ♦ Provides simplified business continuity cluster configuration and management by using the browser-based iManager management tool.
- ♦ Runs on Linux* and NetWare.

1.2.3 Usage Scenarios

There are several Business Continuity Clustering usage scenarios that can be used to achieve the desired level of disaster recovery. Three possible scenarios include:

- ♦ [A Two-Site Business Continuity Cluster Solution](#)
- ♦ [A Multiple-Site Business Continuity Cluster Solution](#)
- ♦ [A Low-Cost Business Continuity Cluster Solution](#)

Two-Site Business Continuity Cluster Solution

The two-site solution can be used in one of two ways:

- ♦ A primary site in which all services are normally active, and a secondary site which is effectively idle, with the data mirrored at it and the applications and services ready to load if needed.
- ♦ Two active sites each supporting different applications and services. Either site can take over for the other site at any time.

The first option is typically used when the purpose of the secondary site is primarily testing by the IT department. The second option is typically used in a company that has more than one large site of operations.

Figure 1-3 Two-Site Business Continuity Cluster

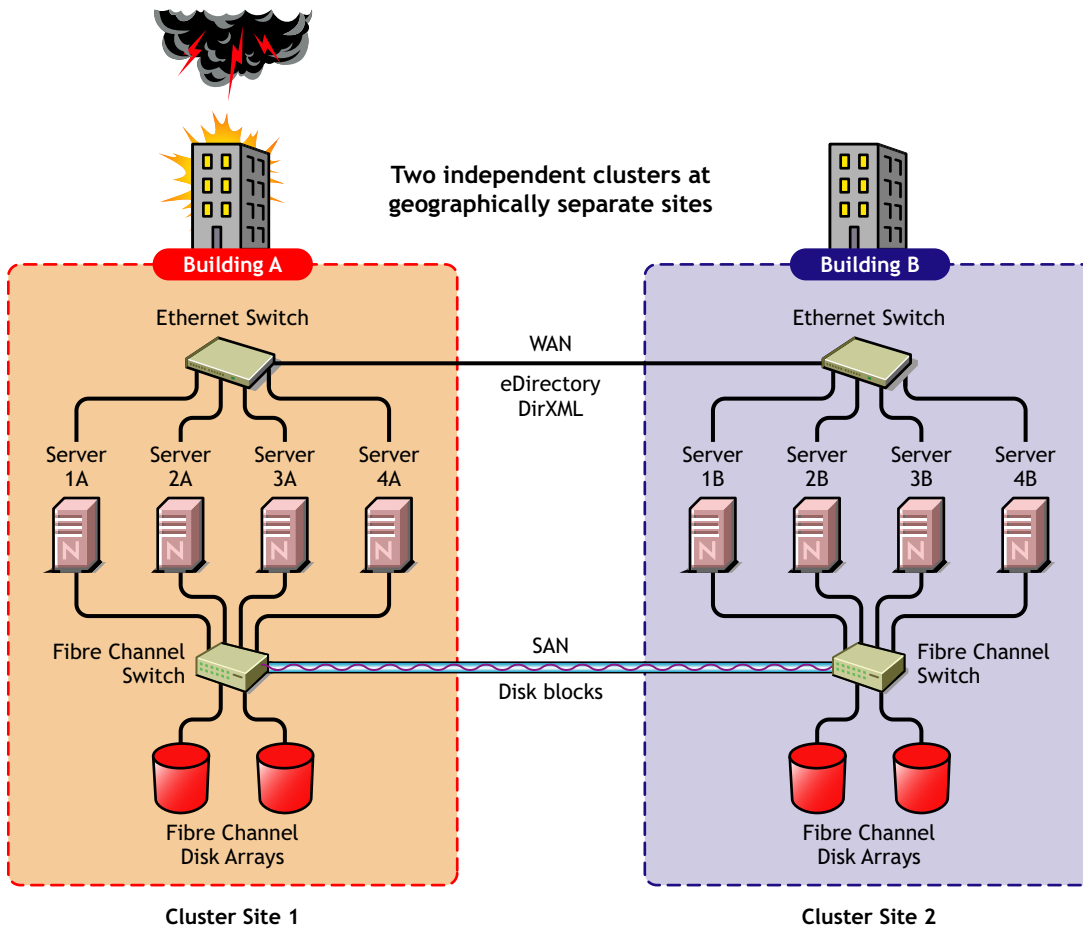

Multiple-Site Business Continuity Cluster Solution

This is a large Business Continuity Cluster solution capable of supporting up to 32 nodes per site and more than two sites. Services and applications can do fan-out failover between sites. Replication of data blocks is typically done by SAN vendors, but can be done by host-based mirroring for synchronous replication over short distances. The illustration below depicts a four-site business continuity cluster.

Figure 1-4 Multiple-Site Business Continuity Cluster

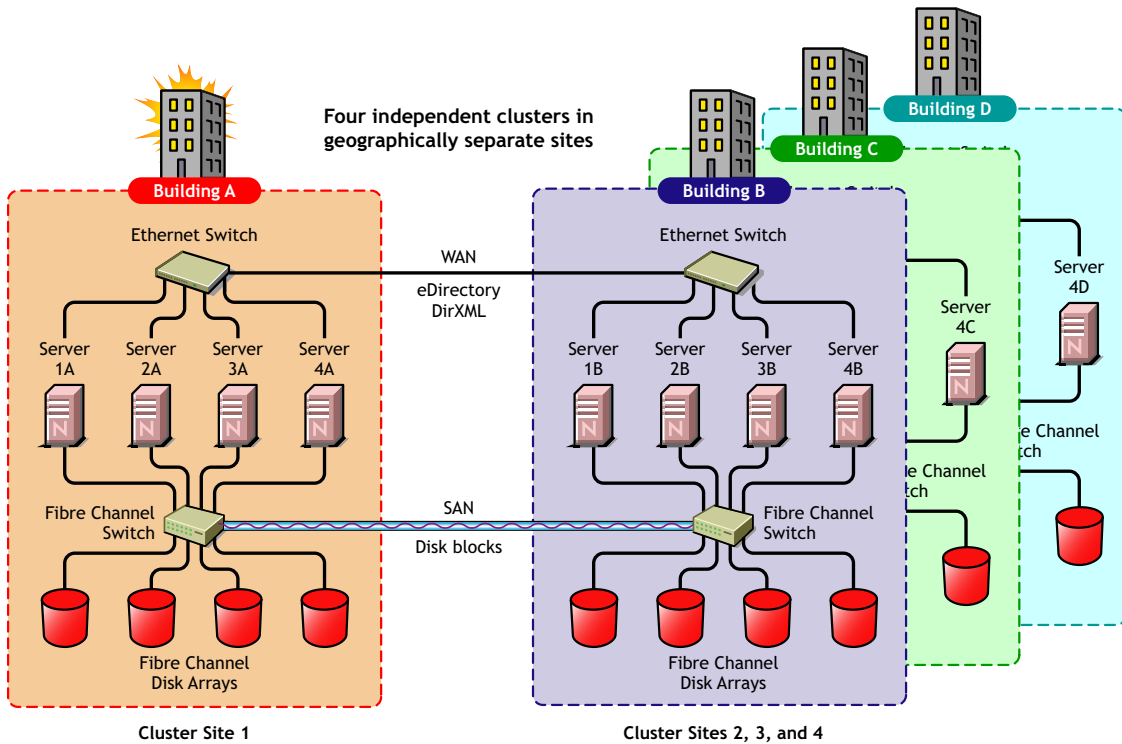

Using the Novell Portal Services, iChain[®], and ZENworks[®] products, all services, applications, and data can be rendered through the Internet, allowing for loss of service at one site but still providing full access to the services and data by virtue of the ubiquity of the Internet. Data and services continue to be available from the other mirrored sites. Moving applications and services to the Internet frees corporations from the restrictions of traditional LAN-based applications. Traditional LAN applications require a LAN infrastructure that must be replicated at each site, and might require relocation of employees to allow the business to continue. Internet-based applications allow employees to work from any place that offers an Internet connection, including homes and hotels.

Low-Cost Business Continuity Cluster Solution

The low-cost business continuity cluster solution is similar to the previous two solutions, but replaces Fibre Channel arrays with iSCSI arrays. Data block mirroring can be accomplished either with iSCSI-based block replication, or host-based mirroring. In either case, snapshot technology can allow for asynchronous replication over long distances. However, the low-cost solution does not necessarily have the performance associated with higher-end Fibre Channel storage arrays.

Installation and Setup

2

This section covers the following information to help you install, set up, and configure Novell® Business Continuity Clustering for your specific needs:

- ◆ Section 2.1, “Requirements,” on page 17
- ◆ Section 2.2, “Installing Novell Business Continuity Clustering Software,” on page 22
- ◆ Section 2.3, “Configuring File System Mirroring,” on page 29
- ◆ Section 2.4, “Setting Up Novell Business Continuity Clustering Software,” on page 33
- ◆ Section 2.5, “Managing a Novell Business Continuity Cluster,” on page 46
- ◆ Section 2.6, “Business Continuity Cluster Failure Types,” on page 52

2.1 Requirements

The requirements in this section must be met prior to installing Novell Business Continuity Clustering software.

- ◆ Section 2.1.1, “Business Continuity Clustering Licensing,” on page 17
- ◆ Section 2.1.2, “NetWare 6.5 SP5 or SP6 (OES 1 SP2 NetWare),” on page 18
- ◆ Section 2.1.3, “Novell eDirectory 8.8,” on page 18
- ◆ Section 2.1.4, “Novell Cluster Services 1.8.2 for NetWare,” on page 19
- ◆ Section 2.1.5, “Novell iManager,” on page 19
- ◆ Section 2.1.6, “Identity Manager,” on page 20
- ◆ Section 2.1.7, “Windows Workstation,” on page 21
- ◆ Section 2.1.8, “OpenSLP,” on page 21
- ◆ Section 2.1.9, “OpenWBEM,” on page 21
- ◆ Section 2.1.10, “BASH,” on page 21
- ◆ Section 2.1.11, “LIBC,” on page 21
- ◆ Section 2.1.12, “autoexec.ncf File,” on page 21
- ◆ Section 2.1.13, “Shared Disk Systems,” on page 21
- ◆ Section 2.1.14, “Link Speeds,” on page 21

2.1.1 Business Continuity Clustering Licensing

Novell Business Continuity Clustering software requires a paper license agreement for each business continuity cluster. For purchasing information, see [Novell Business Continuity Clustering \(http://www.novell.com/products/businesscontinuity/howtobuy.html\)](http://www.novell.com/products/businesscontinuity/howtobuy.html).

2.1.2 NetWare 6.5 SP5 or SP6 (OES 1 SP2 NetWare)

NetWare® 6.5 Support Pack 5 or 6 (the same as Novell Open Enterprise Server 1 Support Pack 2 for NetWare (OES 2 SP2 NetWare)) must be installed and running on all servers that will be part of the business continuity cluster. When NetWare 6.5 SP6 was released, it replaced SP5 in the OES 1 SP2 NetWare downloads.

IMPORTANT: Novell Business Continuity Clustering 1.1 is not supported on NetWare 6.5 Support Pack 7 (same as Novell Open Enterprise Server 2 for NetWare (OES 2 NetWare)) or later.

Using NetWare 6.5 Support Pack 5 also requires the NetWare 6.5 post Support Pack 5 Update. See *OES SP2, NW6.5 SP5 Update 1: TID # 2974185* (<http://support.novell.com/cgi-bin/search/searchtid.cgi?/2974185.htm>). If you have installed NetWare 6.5 Support Pack 6, the Support Pack 5 Update is not required.

See the *NW65 SP8: Installation Guide* for information on installing and configuring NetWare 6.5.

2.1.3 Novell eDirectory 8.8

Novell eDirectory™ 8.8 is supported with Business Continuity Clustering 1.1 Support Pack 1. See the *eDirectory 8.8 documentation* (<http://www.novell.com/documentation/edir88/>) for more information.

IMPORTANT: When you install the Business Continuity Clustering engine software, the eDirectory schema is automatically extended in the eDirectory tree where the BCC software is installed. You need to be able to provide the credentials to authorize the schema extension during the install.

The Identity Manager engine and eDirectory driver must be installed on one node in each cluster. The node where Identity Manager is installed must have an eDirectory full replica with at least read/write access to all eDirectory objects that will be synchronized between clusters. This does not apply to all eDirectory objects in the tree.

IMPORTANT: Full eDirectory replicas are required. Filtered eDirectory replicas are not supported with this version of Business Continuity Clustering software.

The eDirectory full replica must have at least read/write access to the following containers:

- ♦ The Identity Manager driver set container.
- ♦ The container where the Cluster object resides.
- ♦ The container where the server objects reside.

If server objects reside in multiple containers, this must be a container high enough in the tree to be above all containers that contain server objects.

Best practice is to have all server objects in one container.

- ♦ The container where the cluster pool and volume objects are placed when they are synchronized to this cluster. This container is referred to as the landing zone. The NCP server objects for the virtual server of a BCC-enabled resource are also placed in the landing zone.

If the eDirectory full replica does not have read/write access to the containers listed above, cluster resource synchronization and user object synchronization do not work properly.

2.1.4 Novell Cluster Services 1.8.2 for NetWare

You need two to four clusters with Novell Cluster Services™ 1.8.2 (the version that ships with NetWare 6.5 Support Pack 5 and 6 (the same as OES 1 SP2 NetWare) installed and running on each node in the cluster.

Each cluster must have a unique name, even if the clusters reside in different Novell eDirectory trees, and clusters must not have the same name as any of the eDirectory trees in the business continuity cluster.

See the *NW6.5 SP8: Novell Cluster Services 1.8.5 Administration Guide* for information on installing and configuring Novell Cluster Services.

- ♦ The hardware requirements for Novell Business Continuity Clustering software are the same as for Novell Cluster Services. For more information, see “[Hardware Requirements](#)” and “[Software Requirements](#)” in the *NW6.5 SP8: Novell Cluster Services 1.8.5 Administration Guide*.

- ♦ Some SAN vendors require you to purchase or license their CLI (Command Line Interface) separately. The CLI for the SAN might not initially be included with your hardware.

Also, some SAN hardware may not be SMI-S compliant and cannot be managed by using SMI-S commands.

The recommended configuration of a business continuity cluster is to have each Novell Cluster Services cluster be in the same eDirectory tree. You can have a business continuity cluster with clusters in separate eDirectory trees. See [Appendix A, “Implementing a Multiple-Tree BCC,” on page 85](#) for more information.

You must have the `nwcs18pt3` or later cluster patch. See *NetWare Cluster Services Field Test: TID # 2974985* (<http://support.novell.com/docs/Readmes/InfoDocument/2974985.html>). This patch can be applied only to NetWare 6.5 Support Pack 5. If you have upgraded to NetWare 6.5 Support Pack 6, this patch is not required.

In order to add or change cluster peer credentials, you must access iManager on a server that is in the same eDirectory tree as the cluster you are adding or changing peer credentials for.

2.1.5 Novell iManager

Novell iManager (the version released with OES 1 SP2) must be installed and running on a server in the eDirectory tree where you are installing Business Continuity Clustering software. As part of the install process, you will be installing snap-ins for the Identity Manager role that are management templates for configuring a business continuity cluster.

The Identity Manager management utilities should be installed on the same server where you have installed iManager. See “[Business Continuity Cluster Component Locations](#)” on [page 22](#) for specific information on where to install Identity Manager components.

2.1.6 Identity Manager

The Identity Manager 2.x or 3.0.1 engine and the eDirectory driver must be installed on one node in each Novell Cluster Services cluster that you want to be in the business continuity cluster. (Identity Manager was formerly called DirXML[®].) The Identity Manager management utilities must also be installed. The same Identity Manager installation program used to install the Identity Manager engine is also used to install the Identity Manager drivers and management utilities.

- ♦ “Identity Manager 2 Bundle Edition” on page 20
- ♦ “Identity Manager 3 Bundle Edition” on page 20
- ♦ “Installing and Configuring Identity Manager” on page 20

Identity Manager 2 Bundle Edition

Business Continuity Clustering 1.1 and 1.1 Support Pack 1 support Identity Manager 2.x. Identity Manager 2.0.2 is part of the Identity Manager 2 Bundle Edition (formerly referred to as a Starter Pack) that is included with OES 1 SP2. For installation instructions, see “Installing Identity Manager on NetWare” (<http://www.novell.com/documentation/dirxml20/admin/data/abaa2oj.html>) in the *Novell Nsure Identity Manager 2.0.1 Administration Guide*.

NOTE: The Identity Manager 2.0.1 documentation also applies to Identity Manager 2.0.2 and later versions.

Identity Manager 3 Bundle Edition

Identity Manager 3.0.1 is also supported beginning with Business Continuity Clustering 1.1 Support Pack 1. It is included with the Identity Manager 3.0.1 Bundle Edition. Instructions for installing and configuring the Identity Manager 3.0.1 Bundle Edition can be found with the [Identity Manager 3.0.1 Bundle Edition documentation](http://www.novell.com/documentation/oes/implgde/index.html?page=/documentation/oes/implgde/data/b4dgr2g.html#b4dgr2k) (<http://www.novell.com/documentation/oes/implgde/index.html?page=/documentation/oes/implgde/data/b4dgr2g.html#b4dgr2k>).

Installing and Configuring Identity Manager

The node where the Identity Manager engine and the eDirectory driver are installed must have an eDirectory full replica with at least read/write access to all eDirectory objects that will be synchronized between clusters. This does not apply to all eDirectory objects in the tree. For information about the eDirectory full replica requirements, see [Section 2.1.3, “Novell eDirectory 8.8,” on page 18](#).

The Identity Manager management utilities can be installed on a cluster node, but installing them on a non-cluster node is the recommended configuration. The management utilities should be installed on the same server as iManager.

See “[Business Continuity Cluster Component Locations](#)” on page 22 for specific information on where to install Identity Manager components.

2.1.7 Windows Workstation

The Business Continuity Clustering installation program is run from a Windows workstation. Prior to running the installation program:

- ♦ The Windows workstation must have the latest Novell Client™ software installed.
- ♦ You must be authenticated to the eDirectory tree where the cluster resides.

2.1.8 OpenSLP

You must have SLP (Server Location Protocol) set up and configured properly. See “Configuring OpenSLP for eDirectory” (<http://www.novell.com/documentation/edir873/edir873/data/aksbdp5.html#aksbdp5>) in the *Novell eDirectory 8.7.3 Administration Guide*.

2.1.9 OpenWBEM

OpenWBEM must be running and configured to start in `autoexec.ncf`. See the *OpenWBEM Services Administration Guide for OES* (<http://www.novell.com/documentation/oes/cimom/data/front.html#front>).

For the required OpenWBEM patch, see *CIMOM Update for NetWare 6.5 SP6 (Technical Information Document # 5004180)* (http://support.novell.com/docs/Readmes/InfoDocument/patchbuilder/readme_5004180.html).

2.1.10 BASH

BASH must be installed on all nodes that participate in the business continuity cluster. The BASH shell does not need to be running, only installed.

2.1.11 LIBC

You must have the latest LIBC patch installed. This is currently `libcsp6X`. See *LIBC Update NetWare 6.5 SP6 9.00.05 (Technical Information Document # 5003460)* (http://support.novell.com/docs/Readmes/InfoDocument/patchbuilder/readme_5003460.html).

2.1.12 autoexec.ncf File

The `sys:\system\autoexec.ncf` file must be modified so that the call to `sys:/bin/unixenv.ncf` is before the calls to `openwbem.ncf` and `ldbcc.ncf`.

2.1.13 Shared Disk Systems

For Business Continuity Clustering 1.1 on NetWare, a shared disk system (Storage Area Network or SAN) is required for each cluster in the business continuity cluster. See “Shared Disk System Requirements” in the *NW6.5 SP8: Novell Cluster Services 1.8.5 Administration Guide*.

2.1.14 Link Speeds

For real-time mirroring, link speeds should be 1 GB or better, the Fibre Channel cable length between sites should be less than 200 kilometers, and the links should be dedicated.

Many factors should be considered for distances greater than 200 kilometers, some of which include:

- ♦ The amount of data being transferred
- ♦ The bandwidth of the link
- ♦ Whether or not snapshot technology is being used

2.2 Installing Novell Business Continuity Clustering Software

It is necessary to run the Novell Business Continuity Clustering installation program when you want to:

- ♦ Install the Business Continuity Clustering engine software on cluster nodes for the clusters that will be part of a business continuity cluster.

The Business Continuity Clustering installation installs to only one cluster at a time. You must run the installation program again for each NetWare cluster that you want to be part of a business continuity cluster.

- ♦ Install the BCC-specific Identity Manager templates for iManager snap-ins on either a NetWare 6.5 SP5 or SP6 server (same as OES 1 SP2 NetWare) or a Windows* server.

The templates add functionality to iManager so you can manage your business continuity cluster. You must have previously installed iManager on the server where you plan to install the templates.

IMPORTANT: Before you begin, make sure your setup meets the requirements specified in [Section 2.1, “Requirements,”](#) on page 17.

- ♦ [Section 2.2.1, “Business Continuity Cluster Component Locations,”](#) on page 22
- ♦ [Section 2.2.2, “Downloading the Business Continuity Clustering Software,”](#) on page 23
- ♦ [Section 2.2.3, “Configuring a BCC Administrator User,”](#) on page 24
- ♦ [Section 2.2.4, “Installing the Business Continuity Clustering Engine,”](#) on page 27
- ♦ [Section 2.2.5, “Installing the Identity Manager Templates for Business Continuity Clustering,”](#) on page 28

2.2.1 Business Continuity Cluster Component Locations

[Figure 2-1](#) illustrates where the various components needed for a business continuity cluster are installed. For information about the required components, see [Section 2.1, “Requirements,”](#) on page 17.

Figure 2-1 Business Continuity Cluster Component Locations

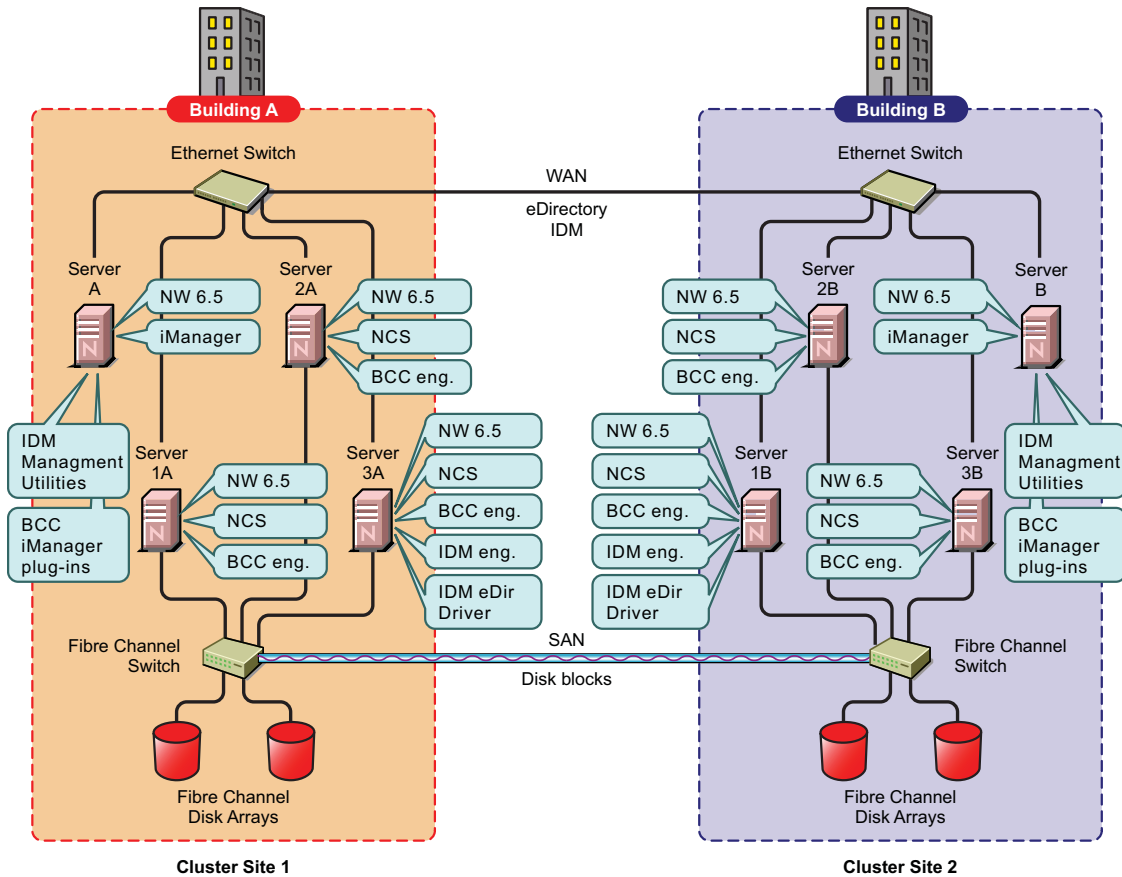

Figure 2-1 uses the following abbreviations:

BCC eng.: Novell Business Continuity Clustering engine

NCS: Novell Cluster Services for NetWare

IDM eng.: Identity Manager engine

IDM eDir Driver: Identity Manager eDirectory driver

eDir: Novell eDirectory

NW 6.5: NetWare 6.5 SP5 or SP6 (the same as Novell Open Enterprise Server 1 Support Pack 2 for NetWare)

2.2.2 Downloading the Business Continuity Clustering Software

Before you install Novell Business Continuity Clustering, download and copy the software to a directory on your Windows workstation. To download Novell Business Continuity Clustering 1.1 with SP1, go to [The Novell Business Continuity Clustering download site \(http://download.novell.com/Download?buildid=bdkmSxRgKVk~\)](http://download.novell.com/Download?buildid=bdkmSxRgKVk~).

2.2.3 Configuring a BCC Administrator User

The BCC Administrator user is a trustee of each of the member Cluster objects in the business continuity cluster. During the install, you specify an existing user to be the BCC Administrator user. This user should have at least Read and Write rights to the All Attribute Rights property on the Cluster object of the remote cluster. The user should also have rights to the `sys:\tmp` directory.

- ♦ “Creating the BCC Administrator User” on page 24
- ♦ “Assigning Trustee Rights for the BCC Administrator User to the Cluster Objects” on page 24
- ♦ “Assigning Trustee Rights for the BCC Administrator User to the `_ADMIN` Volume” on page 24
- ♦ “Assigning Trustee Rights for the BCC Administrator User to the `sys:\tmp` Directory” on page 26

Creating the BCC Administrator User

The BCC Administrator user will be a trustee of each of the member Cluster objects in the business continuity cluster. Identify an existing user, or create a new user, who you want to use as the BCC Administrator user.

Assigning Trustee Rights for the BCC Administrator User to the Cluster Objects

Assign trustee rights to the BCC Administrator user for each cluster that you plan to add to the business continuity cluster.

- 1 Start your Internet browser and enter the URL for iManager.
The URL is `http://server_ip_address/nps/iManager.html`. Replace *server_ip_address* with the IP address or DNS name of the NetWare server or Windows server where you have installed iManager and the Identity Manager preconfigured templates for iManager.
- 2 Specify your username and password, specify the tree where you want to log in, then click *Login*.
- 3 In the *Roles and Tasks* column, click *Rights*, then click the *Modify Trustees* link.
- 4 Specify the Cluster object name, or browse and select it, then click OK.
- 5 If the BCC Administrator user is not listed as a trustee, click the *Add Trustee* button, browse and select the User object, then click *OK*.
- 6 Click *Assigned Rights* for the BCC Administrator user, and then ensure the *Read* and *Write* check boxes are selected for the *All Attributes Rights* property.
- 7 Click *Done* to save your changes.
- 8 Repeat [Step 3](#) through [Step 7](#) for the other clusters in your business continuity cluster.

Assigning Trustee Rights for the BCC Administrator User to the `_ADMIN` Volume

You must also ensure that the BCC Administrator user has file system rights to the `_ADMIN:\Novell\Cluster` directory of each of the nodes in your BCC. This is necessary because the `_ADMIN` volume is virtual, and is created each time the server starts. For this reason, you cannot assign eDirectory trustee rights to the `_ADMIN` volume.

To assign BCC Administrator user file system rights to the `_ADMIN:\Novell\Cluster` directory:

- 1 Open the `sys:\etc\trusttrees.xml` file
- 2 Add a trustee entry for the BCC Administrator user that assigns Read, Write, Modify, and File Scan (RWMF) rights to the `_ADMIN:\Novell\Cluster` directory.
- 3 Repeat this process on all NetWare nodes that are part of your BCC.

The trustee entry could be similar to the following entry:

```
<addTrustee>
  <name>BCCAdmin.users.lab.acme_tree</name>
  <fileName>_ADMIN:\Novell\Cluster</fileName>
  <rights>
    <read/>
    <write/>
    <fileScan/>
    <modify/>
  </rights>
</addTrustee>
```

Note the following items with this example:

- ♦ The `<name>` element is the BCC Administrator user. The tree name is required.
- ♦ The `<filename>` element must be `_ADMIN:\Novell\Cluster`
- ♦ The rights must be RWMF.
- ♦ You must add the trustee entry to all the NetWare nodes in your BCC.

The following is an example of a complete `trustees.xml` file. Note the multiple trustee entries. For this reason you should edit this file and add the BCC entry rather than copy the file from server to server.

```
<specialTrustees>
  <addTrustee>
    <name>BCCAdmin.users.lab.acme_tree</name>
    <fileName>_ADMIN:\Novell\Cluster</fileName>
    <rights>
      <read/>
      <write/>
      <fileScan/>
      <modify/>
    </rights>
  </addTrustee>
  <addTrustee>
    <context />
    <name>[public]</name>
    <fileName>_admin:manage_nss\files.cmd</fileName>
    <rights>
      <read />
```

```

        <write />
        <fileScan />
    </rights>
    <background />
</addTrustee>
</specialTrustees>

```

After the `trustees.xml` file has been modified on all NetWare nodes, the NetWare nodes must be rebooted. This can be done in a rolling fashion. You should start with the node that has the highest IP address first and work down in IP address order. This speeds the rate at which the Novell Cluster Services master node acquires the change.

Assigning Trustee Rights for the BCC Administrator User to the `sys:\tmp` Directory

You must also ensure that the BCC Administrator user is a trustee with Read, Write, Create, Erase, Modify, and File Scan access rights to the `sys:\tmp` directory on every node in your NetWare clusters.

IMPORTANT: If you are concerned about denial of service attacks with the BCC Administrator user, you can set a quota of 5 MB for that user. This can prevent the BCC Administrator user from filling the `sys:` volume by copying an excessive number of files to the `sys:\tmp` directory.

To assign BCC Administrator user file system rights to the `sys:\tmp` directory:

- 1 Open the `sys:\etc\trustees.xml` file
- 2 Add a trustee entry for the BCC Administrator user that assigns Read, Write, Create, Erase, Modify, and File Scan (RWCEMF) rights to the `sys:\tmp` directory.
- 3 Repeat this process on all NetWare nodes that are part of your BCC.

The trustee entry could be similar to the following entry:

```

<addTrustee>
    <name>BCCAdmin.users.lab.acme_tree</name>
    <fileName>sys:\tmp</fileName>
    <rights>
        <read/>
        <write/>
        <create/>
        <erase/>
        <fileScan/>
        <modify/>
    </rights>
</addTrustee>

```

Note the following items with this example:

- ♦ The `<name>` element is the BCC Administrator user. The tree name is required.
- ♦ The `<filename>` element must be `sys:\tmp`
- ♦ The rights must be RWCEMF.
- ♦ You must add the trustee entry to all the NetWare nodes in your BCC.

IMPORTANT: Make sure that you edit each `trustees.xml` file on each cluster node to add the BCC entry rather than copy the file from server to server.

After the `trustees.xml` file has been modified on all NetWare nodes, the NetWare nodes must be rebooted. This can be done in a rolling fashion. You should start with the node that has the highest IP address first and work down in IP address order. This speeds the rate at which the Novell Cluster Services master node acquires the change.

2.2.4 Installing the Business Continuity Clustering Engine

You must install the Business Continuity Clustering engine software on each cluster node for the clusters that will be part of a business continuity cluster. You install the software on the nodes of one cluster at a time.

To install and configure Business Continuity Clustering, complete the following steps:

- 1 From the directory on your Windows workstation where you copied the Business Continuity Clustering software, run `install.exe`.

For download information, see [Section 2.2.2, “Downloading the Business Continuity Clustering Software,”](#) on page 23.

- 2 Continue through the installation wizard until you get to the page that prompts you to select the components to install.
- 3 Select one of the *Identity Manager Templates for iManager* installation options, select the *Novell Business Continuity Clustering* component, then click *Next*.

The templates add functionality to iManager so you can manage your business continuity cluster. You must have previously installed iManager on the server where you plan to install the templates.

Identity Manager Templates for NetWare iManager Servers: Installs the templates on a NetWare iManager server. You will be asked to specify the NetWare server where the templates will be installed later in the installation.

Identity Manager Templates for Windows iManager Servers: Installs the templates on the local Windows iManager server. You will be asked to specify the path to Tomcat (a default path is provided) on the Windows server later in the installation.

Novell Business Continuity Clustering: Installs the core Business Continuity Clustering engine files. This core software must be installed on all nodes in each Novell Cluster Services cluster that will be part of a business continuity cluster.

- 4 Do one of the following:
 - ♦ **NetWare iManager Server:** If you chose to install the Identity Manager iManager templates on a NetWare server, specify the name of the eDirectory tree and the fully distinguished name for the server where you want to install the templates. Then click *Next*.
If you don't know the fully distinguished name for the server, you can browse and select it.
 - ♦ **Windows iManager Server:** If you chose to install the Identity Manager iManager templates on a Windows server, specify the path to Tomcat (a default path is provided) on the server. Then click *Next*.
- 5 Continue through the Upgrade Reminder page, then specify the name of the eDirectory tree and the fully distinguished name for the cluster where you want to install the core software files.

If you don't know the fully distinguished name for the cluster, you can browse and select it.

- 6 Select the servers in the cluster where you want to install the core software files for the Business Continuity Clustering product.

All servers currently in the cluster you specified are listed and are selected by default.

You can choose to automatically start Business Continuity Clustering software on each selected node after the installation is complete. If Business Continuity Clustering software is not started automatically after the installation, you can start it manually later by rebooting the cluster server or by entering `LDBCC` at the server console.

- 7 Enter the name and password of an eDirectory user (or browse and select one) with sufficient rights to manage your BCC. This name should be entered in eDirectory dot format. For example, `admin.servers.novell`.

This user should have at least Read and Write rights to the All Attribute Rights property on the Cluster object of the remote cluster. For information, see [Section 2.2.3, "Configuring a BCC Administrator User,"](#) on page 24.

- 8 Continue through the final installation page, then restart the cluster nodes where Identity Manager is running and where you have upgraded `libc.nlm`.

Restarting the cluster nodes can be performed in a rolling fashion in which one server is restarted while the other servers in the cluster continue running. Then another server is restarted, and then another, until all servers in the cluster have been restarted.

This lets you keep your cluster up and running and lets your users continue to access the network while cluster nodes are being restarted.

- 9 Repeat the above steps for each Novell Cluster Services cluster that will be part of the business continuity cluster.

2.2.5 Installing the Identity Manager Templates for Business Continuity Clustering

After the install, you can use the Business Continuity Clustering install program to install the Identity Manager templates on additional iManager servers in the same tree as the business continuity cluster.

- 1 From the directory on your Windows workstation where you copied the Business Continuity Clustering software, run `install.exe`.

For download information, see [Section 2.2.2, "Downloading the Business Continuity Clustering Software,"](#) on page 23.

- 2 Continue through the installation wizard until you get to the page that prompts you to select the components to install.

- 3 Select one of the *Identity Manager Templates for iManager* installation options, deselect the *Novell Business Continuity Clustering* component, then click *Next*.

The templates add functionality to iManager so you can manage your business continuity cluster. You must have previously installed iManager on the server where you plan to install the templates.

Identity Manager Templates for NetWare iManager Servers: Installs the templates on a NetWare iManager server. You will be asked to specify the NetWare server where the templates will be installed later in the installation.

Identity Manager Templates for Windows iManager Servers: Installs the templates on the local Windows iManager server. You will be asked to specify the path to Tomcat (a default path is provided) on the Windows server later in the installation.

4 Do one of the following:

- ♦ **NetWare iManager Server:** If you chose to install the Identity Manager iManager templates on a NetWare server, specify the name of the eDirectory tree and the fully distinguished name for the server where you want to install the templates. Then click *Next*.
If you don't know the fully distinguished name for the server, you can browse and select it.
- ♦ **Windows iManager Server:** If you chose to install the Identity Manager iManager templates on a Windows server, specify the path to Tomcat (a default path is provided) on the server. Then click *Next*.

5 Continue through to the final installation page.

2.3 Configuring File System Mirroring

Several different methods and scenarios exist for mirroring data between geographically separate sites. Each method has its own strengths and weaknesses. For a Business Continuity Clustering system, you need to choose either host-based mirroring or SAN-based mirroring (also called array-based mirroring) and whether you want the mirroring to be synchronous or asynchronous.

SAN-based synchronous mirroring is preferred and is provided by SAN hardware manufacturers. Host-based synchronous mirroring functionality is included with the NSS file system (NSS mirroring) that is part of NetWare 6.5.

NOTE: The Business Continuity Clustering product does not perform data mirroring. You must separately configure either SAN-based mirroring or host-based mirroring.

NSS mirroring is a checkpoint-based synchronous mirroring solution. Data blocks are written synchronously to multiple storage devices. It is an alternative to SAN array-based synchronous replication options.

IMPORTANT: NSS pool snapshot technology does not work in a business continuity cluster.

Figure 2-2 Synchronous Mirroring

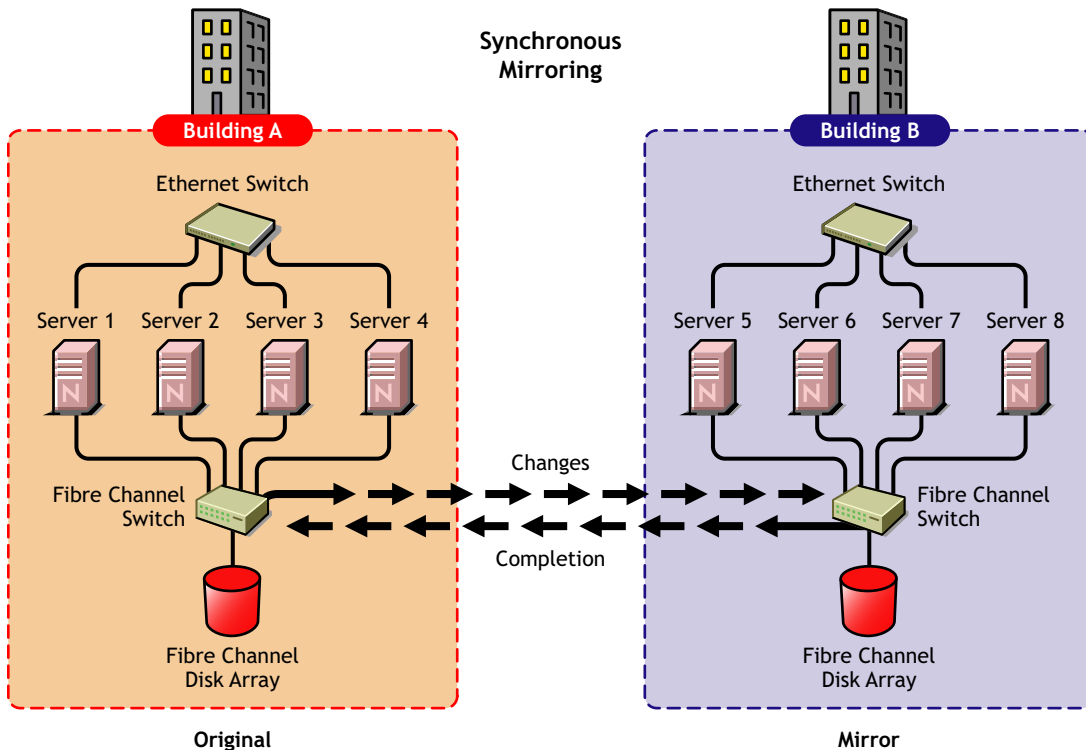

The following sections contain information about configuring the mirroring options:

- ♦ [Section 2.3.1, “Configuring NSS Mirroring,” on page 30](#)
- ♦ [Section 2.3.2, “Configuring SAN-Based Mirroring,” on page 33](#)
- ♦ [Section 2.3.3, “LUN Masking,” on page 33](#)

2.3.1 Configuring NSS Mirroring

NSS partitions must be mirrored after they are created. If you have an existing partition that you want to mirror, you can either create another partition of equal size on another device to mirror the first partition to, or let the mirroring software automatically create another partition of equal size on another device.

When you create a Novell Cluster Services system that utilizes shared storage space (a Storage Area Network or SAN), it is important to remember that all servers attached to the shared device, whether in the cluster or not, have access to all of the volumes on the shared storage space unless you specifically prevent such access. Novell Cluster Services arbitrates access to shared volumes for all cluster nodes, but cannot protect shared volumes from being corrupted by non-cluster servers.

NOTE: Software included with your SAN can be used to mask LUNs or provide zoning capabilities to prevent shared volumes from being corrupted by non-cluster servers.

- ♦ [“Creating and Mirroring NSS Partitions on Shared Storage” on page 31](#)
- ♦ [“Creating an NSS Pool and Volumes” on page 32](#)

- ◆ “Novell Cluster Services Configuration and Setup” on page 32
- ◆ “Checking NSS Volume Mirror Status” on page 32

Creating and Mirroring NSS Partitions on Shared Storage

Prior to creating and mirroring NSS partitions on shared storage, ensure that you have the following:

- ◆ All servers in the cluster connected to a shared storage system
- ◆ One or more drive arrays configured on the shared storage system
- ◆ The drives on the shared storage system marked as shared.

To create and mirror NSS partitions:

- 1 Start NSSMU by entering `NSSMU` at the server console of a cluster server.
- 2 Select *Partitions* from the NSSMU main menu.
- 3 Press the Insert key and select the device on your shared storage system where you want to create a partition.

With a device marked as sharable for clustering, all partitions on that device are automatically sharable.

Device names are not changeable and might be labeled something like 0x2 or 0x1.

- 4 Select *NSS* as the partition type, then specify the partition size and, if desired, an NSS pool name and label.

If you specify a pool name, a pool by that name is automatically created on the partition. If no pool name is specified, you need to create a pool on the partition later.

- 4a If you chose to create a pool, choose whether you want the pool to be activated and cluster-enabled when it is created.

The *Activate on Creation* option is enabled by default. This causes the pool to be activated as soon as it is created. If you choose not to activate the pool, you need to manually activate it later before it can be used.

The *Cluster Enable on Creation* option is also enabled by default. If you want to cluster-enable the pool at the same time it is created, accept the default entry (*Yes*) and continue with [Step 4b](#). If you want to cluster-enable the pool at a later date, see the [NW6.5 SP8: Novell Cluster Services 1.8.5 Administration Guide](#) for more information.

- 4b Specify the *Virtual Server Name*, *IP Address*, *Advertising Protocols* and, if necessary, the *CIFS Server Name*.

When you cluster-enable a pool, a virtual Server object is automatically created and given the name of the Cluster object plus the cluster-enabled pool. For example, if the cluster name is `cluster1` and the cluster-enabled pool name is `pool1`, then the default virtual server name will be `cluster1_pool1_server`. You can edit the field to change the default virtual server name.

Each cluster-enabled NSS pool requires its own IP address. The IP address is used to provide access and failover capability to the cluster-enabled pool (virtual server). The IP address you assign to the pool remains assigned to the pool regardless of which server in the cluster is hosting the pool.

You can select one or all of the advertising protocols. NCP™ is the protocol used by Novell clients, CIFS is the protocol used by Microsoft* clients, and AFP is the protocol used by Macintosh* clients. Selecting any of the protocols causes lines to be added to the

pool resource load and unload scripts to activate the selected protocols on the cluster. This lets you ensure that the cluster-enabled pool you just created is highly available to all your clients.

If you select CIFS as one of the protocols, a *CIFS Server Name* is also required. This is the server name CIFS clients see when they browse the network. A default server name is listed, but you can change the server name by editing the text in the field.

4c Select *Create* to create and cluster-enable the pool.

5 Select the partition you want to mirror (this might be the partition you just created) and press the F3 key.

6 Select the device with free space or the partition you want to mirror to, then select *YES* to mirror the partition.

To ensure disaster recovery, the device you select to mirror should be in another storage array in the other data center.

Creating an NSS Pool and Volumes

After an NSS partition has been created and mirrored, if you have not already done so, you must create an NSS pool and volume on that partition. To do this, follow the instructions in “[Creating Shared NSS Pools](#)” in the “[Installation and Setup](#)” section of the *Novell Cluster Services 1.8.2 Administration Guide for NetWare*.

Novell Cluster Services Configuration and Setup

After configuring NSS mirroring and creating a pool and volume on the mirrored NSS partition, if you did not cluster-enable the NSS pool on the mirrored partition when you created it, do so by following the instructions in the “[Installation and Setup](#)” section of the *Novell Cluster Services 1.8.2 Administration Guide for NetWare*.

When you cluster-enable a shared disk pool, the commands to start and stop the pool resource are automatically added to the resource load and unload scripts.

Checking NSS Volume Mirror Status

After you have configured NSS mirroring with Novell Cluster Services, you should check to ensure that it is working properly in a cluster environment.

1 Ensure that the volumes on the cluster-enabled pool are mounted on the assigned server by entering `volumes` at the server console.

2 Check the mirror status of the mirrored partition by entering `mirror status` at the server console of the server where the NSS pool on the mirrored partition is active.

After entering `mirror status`, you should see a message indicating that mirror status is 100 percent or a message indicating that the mirrored object is fully synchronized.

3 Migrate the pool to another server in the cluster, and check again to ensure that the volumes on the pool are mounted by entering `volumes` at the server console.

4 Check the mirror status of the partition again by entering `mirror status` at the server console.

IMPORTANT: If you create or delete a pool or partition on shared storage that is part of a business continuity cluster, you must run the `cluster scan for new devices` command on a server in each of the other clusters that belong to the business continuity cluster.

2.3.2 Configuring SAN-Based Mirroring

Consult your SAN vendor or SAN vendor documentation for instructions on configuring SAN-based mirroring.

2.3.3 LUN Masking

We recommend that you implement LUN masking in your business continuity cluster for data protection. LUN masking is provided by your SAN vendor.

LUN masking is the ability to exclusively assign each LUN to one or more host connections. With it you can assign appropriately sized pieces of storage from a common storage pool to various servers. See your SAN vendor documentation for more information on configuring LUN masking.

2.4 Setting Up Novell Business Continuity Clustering Software

After you have installed and configured Identity Manager (formerly called DirXML) and the Business Continuity Clustering software, and you have configured file system mirroring, you need to set up the Novell Business Continuity Clustering software.

- ♦ [Section 2.4.1, “Configuring Identity Manager Drivers for the Business Continuity Cluster,” on page 33](#)
- ♦ [Section 2.4.2, “Configuring Clusters for Business Continuity,” on page 38](#)
- ♦ [Section 2.4.3, “Configuring Cluster Resources for Business Continuity,” on page 43](#)

2.4.1 Configuring Identity Manager Drivers for the Business Continuity Cluster

The Identity Manager preconfigured templates for iManager that were installed when you ran the Novell Business Continuity Clustering installation must be configured so you can properly manage your business continuity cluster. The preconfigured templates include the following:

- ♦ **Cluster Resource Synchronization:** This template must always be configured, even in a single-tree business continuity cluster.
- ♦ **User Object Synchronization:** Configuring this template is necessary only if you have more than one eDirectory tree in your business continuity cluster. See [Appendix A, “Implementing a Multiple-Tree BCC,” on page 85](#) for more information.

The Identity Manager engine and eDirectory driver must be installed on one node in each cluster. The node where Identity Manager is installed must have an eDirectory full replica with at least read/write access to all eDirectory objects that will be synchronized between clusters. For information about the full replica requirements, see [Section 2.1.3, “Novell eDirectory 8.8,” on page 18](#).

- ♦ [“Configuring the Identity Manager Drivers and Templates” on page 34](#)
- ♦ [“Creating SSL Certificates” on page 35](#)
- ♦ [“Synchronizing Identity Manager Drivers” on page 36](#)
- ♦ [“Preventing Identity Manager Synchronization Loops” on page 37](#)

Configuring the Identity Manager Drivers and Templates

- 1 Start your Internet browser and enter the URL for iManager.
The URL is `http://server_ip_address/nps/iManager.html`. Replace `server_ip_address` with the IP address or DNS name of the server that has iManager and the Identity Manager preconfigured templates for iManager installed.
- 2 Specify your username and password, specify the tree where you want to log in, then click *Login*.
- 3 In the left column, click *DirXML Utilities*, then click the *New Driver* link.
- 4 Choose to place the new driver in a new driver set, then click *Next*.
Both the *User Object Synchronization* driver and the *Cluster Resource Synchronization* driver can be added to the same driver set.
- 5 Specify the driver set name, context, and the server that the driver set will be associated with.
The server is the same server where you installed the Identity Manager engine and eDirectory driver.
- 6 Choose to *not* create a new partition for the driver set, then click *Next*.
- 7 Choose to import a preconfigured driver from the server, select the Identity Manager preconfigured template for cluster resource synchronization, then click *Next*.
The template name is `BCCClusterResourceSynchronization.XML`.
- 8 Fill in the values on the wizard page as prompted, then click *Next*.

Each field contains an example of the type of information that should go into the field. Descriptions of the information required are also included with each field.

- ♦ **Driver name:** Specify a unique name for this driver to identify its function. For example, *Cluster1SyncCluster2*. If you use both preconfigured templates, you must specify different driver names for each driver template.
- ♦ **Name of SSL Certificate:** If you do not have an SSL certificate, leave this value set to the default. The certificate is created later in the configuration process. See [“Creating SSL Certificates” on page 35](#) for instructions on creating SSL certificates.
- ♦ **DNS name of other IDM node:** Specify the DNS name or IP address of the Identity Manager server in the other cluster.
- ♦ **Port number for this driver:** If you have a business continuity cluster that consists of three or four clusters, you must specify unique port numbers for each driver template set. The default port number is 2002.
You must specify the same port number for the same template in the other cluster. For example, if you specify 2003 as the port number for the resource synchronization template, you must specify 2003 as the port number for the resource synchronization template in the peer driver for the other cluster.
- ♦ **Full Distinguished Name (DN) of the cluster this driver services:** For example, `Cluster1.siteA.Novell`.
- ♦ **Fully Distinguished Name (DN) of the landing zone container:** Specify the context of the container where the cluster pool and volume objects in the other cluster are placed when they are synchronized to this cluster.

This container is referred to as the landing zone. The NCP server objects for the virtual server of a BCC enabled resource are also placed in the landing zone.

IMPORTANT: The context must already exist and must be specified using dot format without the tree name. For example, siteA.Novell.

Prior to performing this step, you could create a separate container in eDirectory specifically for these cluster pool and volume objects. You would then specify the context of the new container in this step.

The IDM Driver object must have sufficient rights to any object it reads or writes in the following containers:

- ◆ The Identity Manager driver set container.
- ◆ The container where the Cluster object resides.
- ◆ The container where the Server objects reside.

If server objects reside in multiple containers, this must be a container high enough in the tree to be above all containers that contain server objects.

Best practice is to have all server objects in one container.

- ◆ The container where the cluster pool and volume objects are placed when they are synchronized to this cluster.

This container is referred to as the landing zone. The NCP server objects for the virtual server of a BCC enabled resource are also placed in the landing zone.

You can do this by making the IDM Driver object security equivalent to another User object with those rights. See [Step 9](#).

IMPORTANT: If you choose to include User object synchronization, exclude the Admin User object from being synchronized. See [Step 7](#) in [Section A.4, “Synchronizing the BCC-specific Identity Manager Drivers,”](#) on page 87 for information about synchronizing User objects when adding new clusters to the business continuity cluster.

9 Make the IDM Driver object security equivalent to an existing User object:

9a Click *Define Security Equivalences*, then click *Add*.

9b Browse to and select the desired User object, then click *OK*.

9c Click *Next*, then click *Finish*.

10 Repeat [Step 1](#) through [Step 9](#) above on the other clusters in your business continuity cluster.

This includes creating a new driver and driver set for each cluster.

IMPORTANT: If you have upgraded to Identity Manager 3 and click either the cluster resource synchronization driver or the user object synchronization driver, a message is displayed prompting you to convert the driver to a new architecture. Click *OK* to convert the driver.

Creating SSL Certificates

It is recommended that you create an SSL certificate for the Cluster Resource Synchronization driver. Creating one certificate creates that certificate for a driver pair. For example, creating an SSL certificate for the Cluster Resource Synchronization driver also creates the certificate for the Cluster Resource Synchronization drivers on the other clusters.

To create an SSL certificate:

- 1 Start your Internet browser and enter the URL for iManager.
The URL is `http://server_ip_address/nps/iManager.html`. Replace `server_ip_address` with the IP address or DNS name of the server that has iManager and the Identity Manager preconfigured templates for iManager installed.
- 2 Specify your username and password, specify the tree where you want to log in, then click *Login*.
- 3 In the left column, click *DirXML Utilities*, then click *NDS-to-NDS Driver Certificates*.
- 4 Specify the requested driver information for this cluster, then click *Next*.
You must specify the driver name (including the context) you supplied in [Step 8 on page 34](#) for this cluster. Use the following format when specifying the driver name:
`DriverName.DriverSet.OrganizationalUnit.OrganizationName`
Ensure that there are no spaces (beginning or end) in the specified context, and do not use the following format:
`cn=DriverName.ou=OrganizationalUnitName.o=OrganizationName`
- 5 Specify the requested driver information for the driver in the other cluster.
Use the same format specified in [Step 4](#).
- 6 Click *Next*, then click *Finish*.

Synchronizing Identity Manager Drivers

After creating the BCC-specific Identity Manager drivers and SSL certificates, if you are adding a new cluster to an existing business continuity cluster, you must synchronize the BCC-specific Identity Manager drivers. If the BCC-specific Identity Manager drivers are not synchronized, clusters can't be enabled for business continuity. Synchronizing the Identity Manager drivers is not necessary unless you are adding a new cluster to an existing business continuity cluster.

NOTE: DirXML is now called Identity Manager in the latest releases.

To synchronize the BCC-specific Identity Manager drivers:

- 1 Start your Internet browser and enter the URL for iManager.
The URL is `http://server_ip_address/nps/iManager.html`. Replace `server_ip_address` with the IP address or DNS name of the server that has iManager and the Identity Manager preconfigured templates for iManager installed.
- 2 Specify your username and password, specify the tree where you want to log in, then click *Login*.
- 3 In the left column, click *DirXML*, then click the *DirXML Overview* link.
- 4 Search for and find the BCC driver set.
- 5 Click the red *Cluster Sync* icon for the driver you want to synchronize, then click the *Migrate from eDirectory* button.
- 6 Click *Add*, browse to and select the Cluster object for the new cluster you are adding to the business continuity cluster, then click *OK*.
Selecting the Cluster object causes the BCC-specific Identity Manager drivers to synchronize.

If you have multiple eDirectory trees in your BCC, see [Section A.4, “Synchronizing the BCC-specific Identity Manager Drivers,”](#) on page 87.

Preventing Identity Manager Synchronization Loops

If you have three or more clusters in your business continuity cluster, you should set up synchronization for the User objects and Cluster Resource objects in a manner that prevents Identity Manager synchronization loops. Identity Manager synchronization loops can cause excessive network traffic and slow server communication and performance.

For example, in a three-cluster business continuity cluster, an Identity Manager synchronization loop occurs when Cluster One is configured to synchronize with Cluster Two, Cluster Two is configured to synchronize with Cluster Three, and Cluster Three is configured to synchronize back to Cluster One. This is illustrated in [Figure 2-3](#) below.

Figure 2-3 Three-Cluster Identity Manager Synchronization Loop

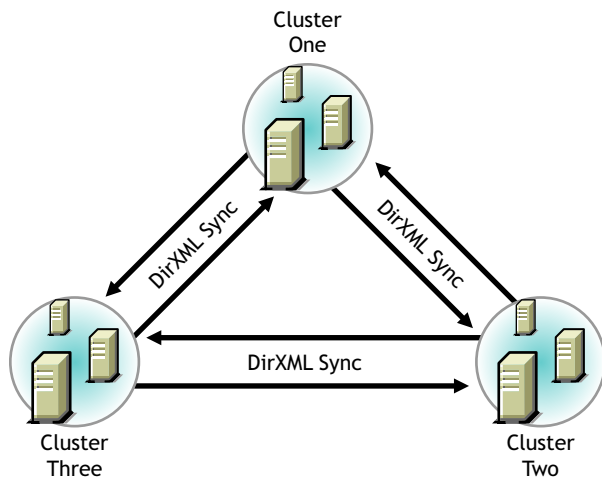

A preferred method is to make Cluster One an Identity Manager synchronization master in which Cluster One synchronizes with Cluster Two, and Cluster Two and Cluster Three both synchronize with Cluster One. This is illustrated in [Figure 2-4](#) below.

Figure 2-4 Three-Cluster Identity Manager Synchronization Master

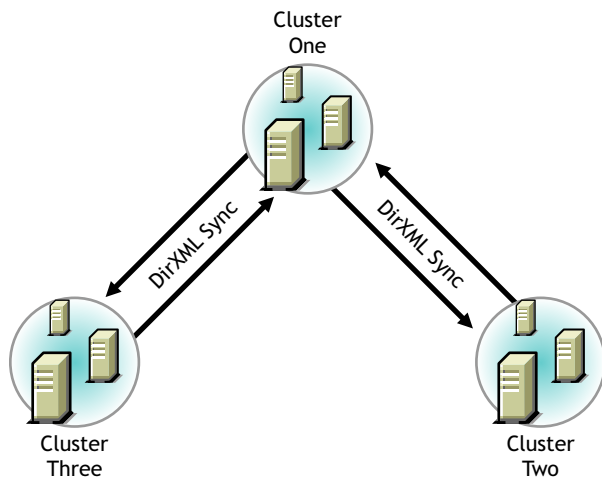

You could also have Cluster One synchronize with Cluster Two, Cluster Two synchronize with Cluster Three, and Cluster Three synchronize back to Cluster Two as illustrated in [Figure 2-5](#).

Figure 2-5 Alternate Three-Cluster Identity Manager Synchronization Scenario

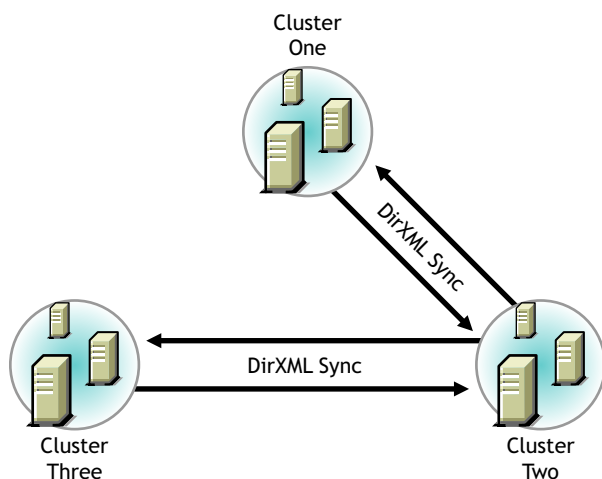

To change your BCC synchronization scenario:

- 1 In the Connections section of the Business Continuity Cluster Properties page, select one or more peer clusters that you want a cluster to synchronize to, then click *Edit*.

In order for a cluster to appear in the list of possible peer clusters, that cluster must have the following:

- ◆ Business Continuity Clustering software installed.
- ◆ Identity Manager installed.
- ◆ The BCC-specific Identity Manager drivers configured and running.
- ◆ Be enabled for business continuity.

2.4.2 Configuring Clusters for Business Continuity

The following tasks must be performed on each separate Novell Cluster Services cluster that you want to be part of the business continuity cluster:

- ◆ [“Enabling Clusters for Business Continuity” on page 39](#)
- ◆ [“Adding Cluster Peer Credentials” on page 39](#)
- ◆ [“Adding Resource Script Search and Replace Values” on page 40](#)
- ◆ [“Adding SAN Management Configuration Information” on page 41](#)
- ◆ [“Verifying BCC Administrator User Trustee Rights and Credentials” on page 43](#)

NOTE: Identity Manager must be configured and running before configuring clusters for business continuity.

Enabling Clusters for Business Continuity

If you want to enable a cluster to fail over selected resources or all cluster resources to another cluster, you must enable business continuity on that cluster.

- 1 Start your Internet browser and enter the URL for iManager.
The URL is `http://server_ip_address/nps/iManager.html`. Replace *server_ip_address* with the IP address or DNS name of the server that has iManager and the Identity Manager preconfigured templates for iManager installed. This server should be in the same eDirectory tree as the cluster you are enabling for business continuity.
- 2 Specify your username and password, specify the tree where you want to log in, then click *Login*.
- 3 Ensure that the BCC-specific Identity Manager drivers are running.
 - 3a In the left column, click *DirXML*, and then click the *DirXML Overview* link.
 - 3b Search the eDirectory Container or tree for the BCC-specific Identity Manager drivers.
 - 3c For each driver, click the upper right corner of the driver icon to see if a driver is started or stopped.
 - 3d If the driver is stopped, start it by selecting *Start*.
- 4 In the left column, click *Clusters*, then click the *Cluster Options* link.
- 5 Specify a cluster name, or browse and select one.
- 6 Click the *Properties* button, then click the *Business Continuity* tab.
- 7 Ensure that the *Enable Business Continuity Features* check box is selected.
- 8 Repeat [Step 1](#) through [Step 7](#) for the other cluster that this cluster will migrate resources to.
- 9 Continue with [Step 1](#) in the [Adding Cluster Peer Credentials](#) section.

Adding Cluster Peer Credentials

In order for one cluster to connect to a second cluster, the first cluster must be able to authenticate to the second cluster. To make this possible, you must add the username and password of the user that the selected cluster will use to connect to the selected peer cluster.

IMPORTANT: In order to add or change cluster peer credentials, you must access iManager on a server that is in the same eDirectory tree as the cluster you are adding or changing peer credentials for.

- 1 In the *Connections* section of the Business Continuity Cluster Properties page, select the peer cluster, then click *Edit*.
In order for a cluster to appear in the list of possible peer clusters, that cluster must have the following:
 - ♦ Business Continuity Clustering software installed.
 - ♦ Identity Manager installed and running.
 - ♦ The BCC-specific Identity Manager drivers configured and running.
 - ♦ Be enabled for business continuity.
- 2 Add the administrator username and password that the selected cluster will use to connect to the selected peer cluster.

When adding the administrator username, do not include the context for the user. For example, use `bccadmin` instead of `bccadmin.prv.novell`.

Rather than using the Admin user to administer your BCC, you should consider creating another user with sufficient rights to the appropriate contexts in your eDirectory tree to manage your BCC. For information, see [Section 2.2.3, “Configuring a BCC Administrator User,” on page 24](#).

- 3 Repeat [Step 1](#) and [Step 2](#) for the other cluster that this cluster will migrate resources to.
- 4 Continue with [Step 1](#) in the [Adding Resource Script Search and Replace Values](#) section.

Adding Resource Script Search and Replace Values

To enable a resource for business continuity, certain values (such as IP addresses) specified in resource load and unload scripts need to be changed in corresponding resources in the other clusters. You need to add the search and replace strings that are used to transform cluster resource load and unload scripts from this cluster to another cluster.

TIP: You can see the IP addresses that are currently assigned to resources by entering the `display secondary ipaddress` command at the NetWare server console of cluster servers.

The search and replace data is cluster-specific, and it is not synchronized via Identity Manager between the clusters in the business continuity cluster.

To add resource script search and replace values:

- 1 In the *Resource Script Replacements* section of the Business Continuity Cluster Properties page, click *New*.
- 2 Add the desired search and replace values, then click *OK*.

The search and replace values you specify here apply to all resources in the cluster that have been enabled for business continuity.

For example, if you specify 10.1.1.1 as the search value and 192.168.1.1 as the replace value, the resource with the 10.1.1.1 IP address in its scripts is searched for in the primary cluster and, if found, the 192.168.1.1 IP address is assigned to the corresponding resource in the secondary cluster.

You can also specify global search and replace addresses for multiple resources in one line. This can be used only if the last digits in the IP addresses are the same in both clusters. For example, if you specify 10.1.1. as the search value and 192.168.1. as the replace value, the software finds the 10.1.1.1, 10.1.1.2, 10.1.1.3 and 10.1.1.4 addresses, and then replaces them with the 192.168.1.1, 192.168.1.2, 192.168.1.3, and 192.168.1.4 addresses, respectively.

IMPORTANT: Make sure to use a trailing dot in the search and replace value. If a trailing dot is not used, 10.1.1 could be replaced with an IP value such as 192.168.100 instead of 192.168.1.

You can select the *Use Regular Expressions* check box to use wildcard characters in your search and replace values. The following links provide information on regular expressions and wildcard characters:

- ♦ [Regular Expressions \(http://www.opengroup.org/onlinepubs/007908799/xbd/re.html\)](http://www.opengroup.org/onlinepubs/007908799/xbd/re.html)
- ♦ [Regular-Expressions.info \(http://www.regular-expressions.info/\)](http://www.regular-expressions.info/)

- ♦ [Wikipedia \(http://en.wikipedia.org/wiki/Regular_expression\)](http://en.wikipedia.org/wiki/Regular_expression)
- ♦ [oreilly.com \(http://www.oreilly.com/catalog/regex/\)](http://www.oreilly.com/catalog/regex/)

You can find additional information on regular expressions and wildcard characters by searching the Web.

Adding SAN Management Configuration Information

You can create scripts and add commands that are specific to your SAN hardware. These scripts and commands might be needed to promote mirrored LUNs to primary on the cluster where the pool resource is being migrated to, or demote mirrored LUNs to secondary on the cluster where the pool resource is being migrated from.

You can also add Perl scripts and add commands to scripts to call other scripts. Any command that can be run at the NetWare server console can be used. The scripts or commands you add are stored in eDirectory. If you add commands to call outside scripts, those scripts must exist on every server in the cluster.

To add SAN management configuration information:

- 1 Start your Internet browser and enter the URL for iManager.
The URL is `http://server_ip_address/nps/iManager.html`. Replace *server_ip_address* with the IP address or DNS name of the server that has iManager and the Identity Manager preconfigured templates for iManager installed.
- 2 Specify your username and password, specify the tree where you want to log in, then click *Login*.
- 3 In the left column, click *Clusters*, then click the *Cluster Options* link.
- 4 Specify a cluster name, or browse and select one.
- 5 Under *Cluster Objects*, select a cluster resource that is enabled for business-continuity, then click *Details*.
Cluster resources that are enabled for business continuity have the BCC label on the resource type icon.
- 6 Click the *Business Continuity* tab, then click *SAN Management*.
- 7 Create BCC SAN management load and unload scripts:
 - 7a Under *BCC Load Scripts*, click *New* to bring up a page that lets you create a script to promote mirrored LUNs on a cluster.
You can also delete a script, edit a script by clicking *Details*, or change the order that load scripts execute by clicking the *Move Up* and *Move Down* links.
 - 7b Specify the values on the SAN Management Script Details page.
Descriptions of the information required for the page fields and options include:
 - ♦ **Name and Description:** Specify a name, and if desired, a description of the script you are creating.
 - ♦ **CIMOM IP/DNS:** If you are not using a template and if you selected the *CIM Client* check box on the previous page, specify the IP address or DNS name for your SAN. This is the IP address or DNS name that is used for SAN management.
 - ♦ **Namespace:** If you selected the *CIM Client* check box on the previous page, accept the default namespace, or specify a different namespace for your SAN.

Namespace determines which models and classes are used with your SAN. Consult your SAN documentation to determine which namespace is required for your SAN.

- ♦ **Username and Password:** If you selected the CIM Client check box on the previous page, specify the username and password that is used to connect to and manage your SAN.
- ♦ **Port:** If you selected the *CIM Client* check box on the previous page, accept the default port number or specify a different port number. This is the port number that CIMOM (your SAN manager) uses. Consult your SAN documentation to determine which port number you should use.
- ♦ **Secure:** If you selected the *CIM Client* check box on the previous page, select or deselect the Secure check box depending whether you want SAN management communication to be secure (HTTPS) or unsecure (HTTP).
- ♦ **Script Parameters:** If desired, specify variables and values for the variables that are used in the SAN management script.

To specify a variable, click *New*, then provide the variable name and value in the fields provided. Click *OK* to save your entries. You can specify additional variables by clicking *New* again and providing variable names and values. You can also edit and delete existing script parameters by clicking the applicable link.

- ♦ **Script Parameters Text Box:** Use this text box to add script commands to the script you are creating.

These script commands are specific to your SAN hardware. You can add a Perl script, or any commands that can be run on Linux or NetWare (depending on your platform). If you add commands to call outside scripts, those scripts must exist on every server in the cluster.

- ♦ **CIM Enabled:** Select this box if your SAN supports SMI-S and you did not select the *CIM Client* check box on the previous page. This causes the CIM-specific fields to become active on this page.
- ♦ **Synchronous:** If this check box is not selected, multiple scripts can be run concurrently. Selecting the box causes scripts to run individually, one after another. Most SAN vendors do not support running multiple scripts concurrently.
- ♦ **Edit Flags:** This is an advanced feature, and should not be used except under the direction of Novell Support.

- 7c** Click *Apply* and *OK* on the Script Details page, then click *OK* on the Resource Properties page to save your script changes.

IMPORTANT: After clicking *Apply* and *OK* on the Script Details page, you are returned to the Resource Properties page (with the *Business Continuity* tab selected). If you do not click *OK* on the Resource Properties page, your script changes are not saved.

IMPORTANT: The CIMOM daemons on all nodes in the business continuity cluster should be configured to bind to all IP addresses on the server.

Business Continuity Clustering connects to the CIMOM by using the master IP address for the cluster. Because the master IP address moves to other nodes during a failover or migration, the CIMOM must be configured to bind to all IP addresses (secondary and primary), rather than just the primary IP address of the host.

You can do this by editing the `openwbem.conf` file. See [“Changing the OpenWBEM CIMOM Configuration”](http://www.novell.com/documentation/oes/cimom/data/bv3wn7m.html#bv3wn7m) (<http://www.novell.com/documentation/oes/cimom/data/bv3wn7m.html#bv3wn7m>) in the *OpenWBEM Services Administration Guide for OES* for more information.

Verifying BCC Administrator User Trustee Rights and Credentials

You must ensure that the user who manages your BCC (BCC Administrator user) is a trustee of the Cluster objects and has at least Read and Write eDirectory rights to the All Attributes Rights property. For instructions, see [“Assigning Trustee Rights for the BCC Administrator User to the Cluster Objects”](#) on page 24.

You must also ensure that the BCC Administrator user has file system rights to the `_ADMIN:\Novell\Cluster` directory of all nodes in your BCC. This is necessary because the `_ADMIN` volume is virtual, and is created each time the server starts. For this reason, you cannot assign eDirectory trustee rights to the `_ADMIN` volume. For instructions, see [“Assigning Trustee Rights for the BCC Administrator User to the _ADMIN Volume”](#) on page 24.

You must also ensure that the BCC Administrator user has Read, Write, Create, Erase, Modify, and File Scan access rights to the `sys:/tmp` directory on every node in your clusters. For instructions, see [“Assigning Trustee Rights for the BCC Administrator User to the sys:\tmp Directory”](#) on page 26.

2.4.3 Configuring Cluster Resources for Business Continuity

Cluster resources can be configured for business continuity after they are created. Configuring a resource for business continuity consists of enabling that resource for business continuity, adding load and unload scripts search and replace data specific to the resource, and selecting peer clusters for the resource.

IMPORTANT: In a business continuity cluster, you should have only one NSS pool for each LUN that could be failed over to another cluster. This is necessary because in a business continuity cluster, entire LUNs fail over to other clusters, rather than individual pools, which fail over to other nodes within a cluster.

A cluster-enabled NSS pool must contain at least one volume before its cluster resource can be enabled for business continuity. You get an error message if you attempt to enable the resource for business continuity if its NSS pool does not contain a volume.

Also, if you have encrypted NSS volumes in your BCC, then all clusters in that BCC must be in the same eDirectory tree. If not, then the clusters in the other eDirectory tree cannot decrypt the NSS volumes. This rule applies to both NetWare and Linux BCCs.

- ◆ [“Enabling a Cluster Resource for Business Continuity”](#) on page 44
- ◆ [“Adding Resource Script Search and Replace Values”](#) on page 44
- ◆ [“Selecting Peer Clusters for the Resource”](#) on page 46
- ◆ [“Adding SAN Array Mapping Information”](#) on page 46

Enabling a Cluster Resource for Business Continuity

Cluster resources must be enabled for business continuity on the primary cluster before they can be synchronized and appear as resources in the other clusters in the business continuity cluster. Enabling a cluster resource makes it possible for that cluster resource or cluster pool resource to be migrated to another cluster.

IMPORTANT: Although you can add search and replace data that is resource-specific after you enable a resource for business continuity, we recommend adding the search and replace data for the entire cluster before you enable resources for business continuity. See “[Adding Resource Script Search and Replace Values](#)” on page 40 for instructions on adding search and replace data for the entire cluster.

When you enable a resource for business continuity and that resource has been synchronized and appears in the other clusters, the preferred nodes for the other clusters are by default set to all nodes in the cluster. If you want to change the resource’s preferred nodes for other clusters in your BCC, you must manually do it. Changes to the preferred nodes list in the primary cluster do not automatically replicate to the preferred nodes lists for other clusters in your BCC.

- 1** (Conditional) If you are creating a new cluster resource or cluster pool resource, follow the instructions for creating a cluster resource or cluster pool resource using iManager in the [NW6.5 SP8: Novell Cluster Services 1.8.5 Administration Guide](#), then continue with [Step 2](#).
- 2** Enable a cluster resource or cluster pool resource for business continuity:
 - 2a** Start your Internet browser and enter the URL for iManager.

The URL is `http://server_ip_address/nps/iManager.html`. Replace *server_ip_address* with the IP address or DNS name of the server that has iManager and the Identity Manager preconfigured templates for iManager installed.
 - 2b** Specify your username and password, specify the tree where you want to log in, then click *Login*.
 - 2c** In the left column, click *Clusters*, then click the *Cluster Options* link.
 - 2d** Specify a cluster name, or browse and select one.
 - 2e** Select the desired cluster resource from the list of Cluster objects.
 - 2f** Click the *Details* link, then click the *Business Continuity* tab.
- 3** Ensure that the *Enable Business Continuity Features* check box is selected.
- 4** Continue with [Step 1](#) in the [Adding Resource Script Search and Replace Values](#) section.

Adding Resource Script Search and Replace Values

If you did not previously add search and replace data specific to the entire cluster, you must now add it for this resource.

IMPORTANT: Adding resource script search and replace values for the entire cluster is recommended rather than adding those values for individual cluster resources. You should contact Novell Support prior to adding search and replace values for individual cluster resources.

To enable a resource for business continuity, certain values (such as IP addresses, DNS names, and tree names) specified in resource load and unload scripts need to be changed in corresponding resources in the other clusters. You need to add the search and replace strings that are used to transform cluster resource load and unload scripts from this cluster to another cluster.

The search and replace data you add is resource-specific, and it is not synchronized via Identity Manager between the clusters in the business continuity cluster.

To add resource script search and replace values specific to this resource:

1 In the *Resource Replacement Script* section of the page, click *New*.

If a resource has already been configured for business continuity, you can click *Edit* to change existing search and replace values or click *Delete* to delete them.

2 Add the desired search and replace values, then click *OK*.

The search and replace values you specify here apply to only to the resource you are enabling for business continuity. If you want the search and replace values to apply to any or all cluster resources, add them to the entire cluster instead of just to a specific resource.

See “[Adding Resource Script Search and Replace Values](#)” on page 40 for more information on resource script search and replace values and adding those values to the entire cluster.

3 Do one of the following:

- ◆ If this is an existing cluster resource, continue with [Step 1](#) in the [Selecting Peer Clusters for the Resource](#) section below.
- ◆ If you are creating a new cluster resource, click *Next*, then continue with [Step 1](#) in the [Selecting Peer Clusters for the Resource](#) section.

You can select the Use Regular Expressions check box to use wildcard characters in your search and replace values. The following links provide information on regular expressions and wildcard characters:

- ◆ [Regular Expressions](http://www.opengroup.org/onlinepubs/007908799/xbd/re.html) (<http://www.opengroup.org/onlinepubs/007908799/xbd/re.html>)
- ◆ [Regular-Expressions.info](http://www.regular-expressions.info/) (<http://www.regular-expressions.info/>)
- ◆ [Wikipedia](http://en.wikipedia.org/wiki/Regular_expression) (http://en.wikipedia.org/wiki/Regular_expression)
- ◆ [oreilly.com](http://www.oreilly.com/catalog/regex/) (<http://www.oreilly.com/catalog/regex/>)

You can find additional information on regular expressions and wildcard characters by searching the Web.

IMPORTANT: If you change the resource-specific search and replace data after initially adding it, you must update the resource load and unload script in one of the other clusters by editing it and adding a space or a comment to it. This causes the script to be updated with the new search and replace data.

You could also update the IP address on the cluster protocols page in iManager to cause IP address search and replace values to be updated for both load and unload scripts. This might require you to go back and change the IP addresses specified in the resource load and unload scripts in the source cluster to their original values.

Selecting Peer Clusters for the Resource

Peer clusters are the other clusters that this cluster resource can be migrated to. The cluster or clusters that you select determine where the resource can be manually migrated. If you decide to migrate this resource to another cluster, you must migrate it to one of the clusters that has been selected.

- 1 Select the other clusters that this resource can be migrated to.
- 2 Do one of the following:
 - ♦ If you are creating a new non-pool cluster resource that contains a Reiser or Ext3 file system, click *Finish*.
 - ♦ If this is an existing non-pool cluster resource that contains a Reiser or Ext3 file system, click *Apply*.
 - ♦ If you are creating a new cluster pool resource, click *Next*, then add the SAN management configuration information. For information, see [“Adding SAN Management Configuration Information” on page 41](#).
 - ♦ If this is an existing cluster pool resource, add the SAN management configuration information. For information, see [“Adding SAN Management Configuration Information” on page 41](#).

Adding SAN Array Mapping Information

For information on adding SAN array mapping information, see [“Adding SAN Management Configuration Information” on page 41](#).

2.5 Managing a Novell Business Continuity Cluster

After you have installed, set up, and configured Novell Business Continuity Clustering software and resources, some additional information can be useful to help you effectively manage your business continuity cluster. This information consists of instructions for migrating resources from one cluster to another, changing existing cluster peer credentials, and generating a business continuity report that provides cluster configuration and status information.

See the following sections for this additional information:

- ♦ [Section 2.5.1, “Migrating a Cluster Resource to Another Cluster,” on page 46](#)
- ♦ [Section 2.5.2, “Changing Cluster Peer Credentials,” on page 48](#)
- ♦ [Section 2.5.3, “Viewing the Current Status of a Business Continuity Cluster,” on page 48](#)
- ♦ [Section 2.5.4, “Generating a Cluster Report,” on page 49](#)
- ♦ [Section 2.5.5, “Disabling Business Continuity Cluster Resources,” on page 49](#)
- ♦ [Section 2.5.6, “Business Continuity Cluster Console Commands,” on page 50](#)

2.5.1 Migrating a Cluster Resource to Another Cluster

Although there is now an automatic failover feature for Novell Business Continuity Clustering, it is recommended that you manually migrate resources from one cluster to another cluster. See [Appendix B, “Setting Up Auto-Failover,” on page 91](#). If the node where a resource is running fails,

if the entire cluster fails, or if you just want to migrate the resource to another cluster, you can manually start the cluster resource on another cluster in the business continuity cluster. If the source cluster site fails, you must go to the destination cluster site to manually migrate or bring up resources at that site. Each resource starts on its preferred node on the destination cluster.

TIP: You can use the `cluster migrate` command to start resources on nodes other than the preferred node on the destination cluster.

To manually migrate cluster resources from one cluster to another:

- 1 Start your Internet browser and enter the URL for iManager.
The URL is `http://server_ip_address/nps/iManager.html`. Replace *server_ip_address* with the IP address or DNS name of the server that has iManager and the Identity Manager preconfigured templates for iManager installed.
- 2 Specify your username and password, specify the tree where you want to log in, then click *Login*.
- 3 In the left column, click *Clusters*, then click the *BCC Manager* link.
- 4 Specify a cluster name, or browse and select one.
- 5 Select one or more cluster resources, then click *BCC Migrate*.
- 6 Select the cluster where you want to migrate the selected resources, then click *OK*.
The resources migrate to their preferred node on the destination cluster. If you select *Any Configured Peer* as the destination cluster, the Business Continuity Clustering software chooses a destination cluster for you. The destination cluster that is chosen is the first cluster that is up in the peer clusters list for this resource.

Migrating a pool resource to another cluster causes the following to happen:

1. If the source cluster can be contacted, the state of the resource is changed to offline.
2. The resource changes from primary to secondary on the source cluster.
3. Any SAN script that is associated with the pool resource is run.
4. On the destination cluster, the resource changes from secondary to primary so that it can be brought online.

A custom Perl script can be created for disk mapping on Fibre Channel SANs. The purpose of this script is to make the LUNs in the SAN available to the destination cluster. A reverse script is also created for testing purposes so pool resources can be migrated back to the source cluster.

5. The `cluster scan for new devices` command is executed on the destination cluster so that the cluster is aware of LUNs that are now available.
6. Resources are brought online and load on the their most preferred node in the cluster.
7. Resources appear as running and primary on the cluster where you have migrated them.

WARNING: Do not migrate resources for a test failover if the peer (LAN) connection between the source and destination cluster is down. Possible disk problems and data corruption could occur. This warning does not apply if resources are migrated during an actual cluster site failure.

2.5.2 Changing Cluster Peer Credentials

Changing cluster peer credentials consists of changing the username and password for the administrative user that the selected cluster will use to connect to a selected peer cluster. You might need to do this if the administrator username or password changes for any clusters in the business continuity cluster.

- 1 Start your Internet browser and enter the URL for iManager.

The URL is `http://server_ip_address/nps/iManager.html`. Replace *server_ip_address* with the IP address or DNS name of the server that has iManager and the Identity Manager preconfigured templates for iManager installed.

IMPORTANT: In order to add or change cluster peer credentials, you must access iManager on a server that is in the same eDirectory tree as the cluster you are adding or changing peer credentials for.

- 2 Specify your username and password, specify the tree where you want to log in, then click *Login*.
- 3 In the left column, click *Cluster Administration*, then click the *Management* link.
- 4 Specify a cluster name, or browse and select one.
- 5 Click *Connections* and select a peer cluster.
- 6 Edit the administrator username and password that the selected cluster will use to connect to the selected peer cluster, then click *OK*.

When specifying a username, you don't need to include the Novell eDirectory context for the user name.

NOTE: If the business continuity cluster has clusters in multiple eDirectory trees, and you specify a common username and password, each eDirectory tree in the business continuity cluster must have the same username and password.

2.5.3 Viewing the Current Status of a Business Continuity Cluster

You can view the current status of your business continuity cluster by using either iManager or the server console of a cluster in the business continuity cluster.

Using iManager

- 1 Start your Internet browser and enter the URL for iManager.

The URL is `http://server_ip_address/nps/iManager.html`. Replace *server_ip_address* with the IP address or DNS name of the server that has iManager and the Identity Manager preconfigured templates for iManager installed.

- 2 Specify your username and password, specify the tree where you want to log in, then click *Login*.
- 3 In the left column, click *Clusters*, then click the *BCC Manager* link.
- 4 Specify a cluster name, or browse and select one.

Using this page, you can see if all cluster peer connections are up or if one or more peer connections are down. You can also see the status of the BCC resources in the business continuity cluster.

Using the Server Console

At the server console of a server in the business continuity cluster, enter the following commands to get different kinds of status information:

```
cluster view
```

```
cluster status
```

```
cluster connections
```

2.5.4 Generating a Cluster Report

You can generate a report for each cluster in the business continuity cluster to list information on a specific cluster, such as current cluster configuration, cluster nodes, and cluster resources. You can print or save the report by using your browser.

- 1 Start your Internet browser and enter the URL for iManager.
The URL is `http://server_ip_address/nps/iManager.html`. Replace *server_ip_address* with the IP address or DNS name of the server that has iManager and the Identity Manager preconfigured templates for iManager installed.
- 2 Specify your username and password, specify the tree where you want to log in, then click *Login*.
- 3 In the left column, click *Clusters*, then click the *Cluster Manager* link.
- 4 Specify a cluster name, or browse and select one.
- 5 Click the *Run Report* button.

2.5.5 Disabling Business Continuity Cluster Resources

After enabling a resource for business continuity, it is possible to disable it. You might want to do this if you accidentally enabled the resource for business continuity, or if you no longer want a specific resource to potentially run on another cluster.

- 1 Start your Internet browser and enter the URL for iManager.
The URL is `http://server_ip_address/nps/iManager.html`. Replace *server_ip_address* with the IP address or DNS name of the server that has iManager and the Identity Manager preconfigured templates for iManager installed.
- 2 Specify your username and password, specify the tree where you want to log in, then click *Login*.
- 3 In the left column, click *Clusters*, then click the *Cluster Options* link.
- 4 Specify the cluster name, or browse and select it.
- 5 Select the desired cluster resource from the list of Cluster objects
- 6 Click the *Details* link, then click the *Business Continuity* tab.
- 7 Deselect the *Enable Business Continuity Features* check box, then click *Apply*.
- 8 Wait for Identity Manager to synchronize the changes.

This could take from 30 seconds to one minute, depending on your configuration.

- 9 Delete the Cluster Resource object on the clusters where you no longer want the resource to run.

IMPORTANT: If you disable Business Continuity Clustering for a cluster by using either iManager or the `cluster disable` console command, the cluster resources in that cluster that have been enabled for business continuity are automatically disabled for business continuity. If you re-enable Business Continuity Clustering for the cluster, you must again re-enable each of its cluster resources that you want to be enabled for business continuity.

This can be a time-consuming process if you have many cluster resources that are enabled for business continuity. For this reason, you should use caution when disabling Business Continuity Clustering for an entire cluster.

2.5.6 Business Continuity Cluster Console Commands

Novell Business Continuity Clustering (BCC) Services provides some server console commands to help you perform certain business continuity cluster-related tasks. Some of the commands can be used both with Novell Cluster Services and with Novell Business Continuity Clustering. [Table 2-1](#) lists the BCC-related server console commands and gives a brief description of each command. For other cluster console commands, see “[Console Commands for Novell Cluster Services](#)” in the *NW6.5 SP8: Novell Cluster Services 1.8.5 Administration Guide*.

To execute a cluster console command, enter `cluster` followed by the command. For example, if this cluster is a member of a business continuity cluster, and you want to see this cluster's peer clusters, enter `cluster view` at the server console. You can also enter `cluster help` at the console prompt to get information on the commands and their functions.

Table 2-1 Console Commands for Novell Business Continuity Clustering

Console Command	Description
<code>cluster credentials [cluster]</code>	Lets you change the administrator username and password that this cluster uses to connect to the specified peer cluster. The cluster you specify must be a member of a cluster that has already been enabled for Business Continuity Clustering.

Console Command	Description
<code>cluster disable [resource]</code>	<p>Disables Business Continuity Clustering for the specified resource. The resource you specify must be a member of a cluster that has already been enabled for Business Continuity Clustering. If no resource is specified, the entire cluster is disabled for Business Continuity Clustering.</p> <p>If you disable Business Continuity Clustering for a cluster by using the <code>cluster disable</code> console command, it is also disabled for those cluster resources that have been enabled for Business Continuity Clustering. If you re-enable Business Continuity Clustering for the cluster, you must re-enable each individual cluster resource that you want to be enabled for business continuity.</p> <p>This can be a time-consuming process if you have many cluster resources that are enabled for business continuity. For this reason, you should use caution when disabling Business Continuity Clustering for an entire cluster.</p>
<code>cluster enable [resource]</code>	<p>Enables Business Continuity Clustering for the specified resource. The resource you specify must be a member of a cluster that has already been enabled for Business Continuity Clustering. If no resource is specified, the entire cluster is enabled for Business Continuity Clustering.</p> <p>When enabling a resource for business continuity, previous versions of the CLI would not set the peer clusters where the resource was assigned to run. The only way to set peer clusters for a resource was through iManager. The new version of the cluster CLI automatically sets all the clusters in the BCC on a resource. Assigning a resource to specific clusters still must be done through iManager.</p>
<code>cluster migrate [source/resource] [destination/nodename]</code>	<p>Migrates the specified resource from the specified source cluster to the specified target (destination) cluster. Specifying <code>*</code> for the resource name migrates all BCC-enabled resources. Specifying <code>*</code> for the node name brings the resource online at the most preferred node.</p>

Console Command	Description
<code>cluster resetresources</code>	<p>Changes the state of all resources on this cluster to offline and secondary. This is a recovery procedure that should be run when a cluster in a BCC is brought back into service.</p> <p>You should run this command when only one node is a member of the cluster.</p> <ol style="list-style-type: none"> 1. After a failure, bring up one node in the cluster. <p>All other nodes should remain powered off.</p> 2. Run the <code>cluster resetresources</code> command. 3. Bring up the remaining nodes in the cluster.
<code>cluster view</code>	Displays the node name, cluster epoch number, master node name, a list of nodes that are currently members of the cluster, and peer clusters if this cluster is a member of a Business Continuity Cluster.
<code>cluster resources [resource]</code>	Lets you view the state and location of cluster resources and whether resources are primary or secondary. You can optionally specify a specific resource name.
<code>cluster status</code>	Lets you view the state and location of cluster resources and whether resources are primary or secondary. If the resource state is primary, the node where the resource is running is displayed. If the resource state is secondary, the cluster where the resource is located is displayed.
<code>cluster connections [-a]</code>	Displays the connection status of the cluster. Specifying <code>-a</code> attempts to show the connection status of all clusters in the BCC.
<code>cluster refresh</code>	This command should not be used except under the direction of Novell Support.

2.6 Business Continuity Cluster Failure Types

There are several failure types associated with a business continuity cluster that you should be aware of. Understanding the failure types and knowing how to respond to each can help you more quickly recover a cluster. Some of the failure types and responses differ depending on whether you have implemented SAN-based mirroring or host-based mirroring. Promoting or demoting LUNs is sometimes necessary when responding to certain types of failures.

NOTE: The terms *promote* and *demote* are used here in describing the process of changing LUNs to a state of primary or secondary, but your SAN vendor documentation might use different terms such as *mask* and *unmask*.

- ◆ [Section 2.6.1, “SAN-based Mirroring Failure Types and Responses,” on page 53](#)
- ◆ [Section 2.6.2, “Host-Based Mirroring Failure Types and Responses,” on page 54](#)

2.6.1 SAN-based Mirroring Failure Types and Responses

SAN-based mirroring failure types and responses are described in the following sections:

- ♦ “Primary Cluster Fails but Primary SAN Does Not” on page 53
- ♦ “Primary Cluster and Primary SAN Both Fail” on page 53
- ♦ “Secondary Cluster Fails but Secondary SAN Does Not” on page 53
- ♦ “Secondary Cluster and Secondary SAN Both Fail” on page 53
- ♦ “Primary SAN Fails but Primary Cluster Does Not” on page 54
- ♦ “Secondary SAN Fails but Secondary Cluster Does Not” on page 54
- ♦ “Intersite SAN Connectivity Is Lost” on page 54
- ♦ “Intersite LAN Connectivity Is Lost” on page 54

Primary Cluster Fails but Primary SAN Does Not

This type of failure can be temporary (transient) or long-term. There should be an initial response and then a long-term response based on whether the failure is transient or long-term. The initial response is to restore the cluster to normal operations. The long-term response is total recovery from the failure.

Promote the secondary LUN to primary. Cluster resources load (and become primary on the second cluster). If the former primary SAN has not been demoted to secondary, you might need to demote it manually. The former primary SAN must be demoted to secondary before bringing cluster servers back up. Consult your SAN hardware documentation for instructions on demoting and promoting SANs. You can use the `cluster resetresources` console command to change resource states to offline and secondary.

Prior to bringing up the cluster servers, you must ensure that the SAN is in a state in which the cluster resources cannot come online and cause a divergence in data. Divergence in data occurs when connectivity between SANs has been lost and both clusters assert that they have ownership of their respective disks.

Primary Cluster and Primary SAN Both Fail

Bring the primary SAN back up and follow your SAN vendor’s instructions to remirror and, if necessary, promote the former primary SAN back to primary. Then bring up the former primary cluster servers and fail back the cluster resources.

Secondary Cluster Fails but Secondary SAN Does Not

No additional response is necessary for this failure other than recovering the secondary cluster. When you bring the secondary cluster back up, the LUNs will still be in a secondary state to the primary SAN.

Secondary Cluster and Secondary SAN Both Fail

Bring the secondary SAN back up and follow your SAN vendor's instructions to remirror. When you bring the secondary cluster back up, the LUNs are still in a secondary state to the primary SAN.

Primary SAN Fails but Primary Cluster Does Not

When the primary SAN fails, the primary cluster also fails. Bring the primary SAN back up and follow your SAN vendor's instructions to remirror and, if necessary, promote the former primary SAN back to primary. You might need to demote the LUNs and resources to secondary on the primary SAN before bringing them back up. You can use the `cluster resetresources` console command to change resource states to offline and secondary. Bring up the former primary cluster servers and fail back resources.

Secondary SAN Fails but Secondary Cluster Does Not

When the secondary SAN fails, the secondary cluster also fails. Bring the secondary SAN back up and follow your SAN vendor's instructions to remirror. Then bring the secondary cluster back up. When you bring the secondary SAN and cluster back up, resources are still in a secondary state.

Intersite SAN Connectivity Is Lost

Recover your SANs first, then remirror from the good side to the bad side.

Intersite LAN Connectivity Is Lost

Users might not be able to access servers in the primary cluster but can possibly access servers in the secondary cluster. If both clusters are up, nothing additional is required. An error is displayed. Wait for connectivity to resume.

If you have configured the automatic failover feature, see [Appendix B, "Setting Up Auto-Failover," on page 91](#).

2.6.2 Host-Based Mirroring Failure Types and Responses

- ♦ ["Primary Cluster Fails but Primary SAN Does Not" on page 54](#)
- ♦ ["Primary Cluster and Primary SAN Both Fail" on page 55](#)
- ♦ ["Secondary Cluster Fails but Secondary SAN Does Not" on page 55](#)
- ♦ ["Secondary Cluster and Secondary SAN Both Fail" on page 55](#)
- ♦ ["Primary SAN Fails but Primary Cluster Does Not" on page 55](#)
- ♦ ["Secondary SAN Fails but Secondary Cluster Does Not" on page 55](#)
- ♦ ["Intersite SAN Connectivity is Lost" on page 55](#)
- ♦ ["Intersite LAN Connectivity is Lost" on page 55](#)

Primary Cluster Fails but Primary SAN Does Not

Response for this failure is the same as for SAN-based mirroring described in [Primary Cluster Fails but Primary SAN Does Not](#) in [Section 2.6.1, "SAN-based Mirroring Failure Types and Responses," on page 53](#). Do not disable MSAP (Multiple Server Activation Prevention), which is enabled by default.

Primary Cluster and Primary SAN Both Fail

Bring up your primary SAN or iSCSI target before bringing up your cluster servers. Then run the `Cluster Scan For New Devices` command from a secondary cluster server. Ensure that remirroring completes before bringing down cluster servers back up.

If necessary, promote the former primary SAN back to primary. Then bring up the former primary cluster servers and fail back the cluster resources.

Secondary Cluster Fails but Secondary SAN Does Not

No additional response is necessary for this failure other than recovering the secondary cluster. When you bring the secondary cluster back up, the LUNs will still be in a secondary state to the primary SAN.

Secondary Cluster and Secondary SAN Both Fail

Bring up your secondary SAN or iSCSI target before bringing up your cluster servers. Then run the `Cluster Scan For New Devices` command on a primary cluster server to ensure that remirroring takes place. When you bring the secondary cluster back up, the LUNs are still in a secondary state to the primary SAN.

Primary SAN Fails but Primary Cluster Does Not

If your primary SAN fails, all nodes in your primary cluster also fail. Bring up your primary SAN or iSCSI target and then bring up your cluster servers. Then run the `Cluster Scan For New Devices` command from a secondary cluster server. Ensure that remirroring completes before bringing down cluster servers back up.

If necessary, promote the former primary SAN back to primary. You might need to demote the LUNs and resources to secondary on the primary SAN before bringing them back up. You can use the `cluster resetresources` console command to change resource states to offline and secondary. Bring up the former primary cluster servers and fail back resources.

Secondary SAN Fails but Secondary Cluster Does Not

Bring up your secondary SAN or iSCSI target before bringing up your cluster servers. Then run the `Cluster Scan For New Devices` command on a primary cluster server to ensure remirroring takes place. Then bring the secondary cluster back up. When you bring the secondary SAN and cluster back up, resources are still in a secondary state.

Intersite SAN Connectivity is Lost

You must run the `Cluster Scan For New Devices` command on both clusters to ensure remirroring takes place. Recover your SANs first, then remirror from the good side to the bad side.

Intersite LAN Connectivity is Lost

Users might not be able to access servers in the primary cluster but can possibly access servers in the secondary cluster. If both clusters are up, nothing additional is required. An error is displayed. Wait for connectivity to resume.

If you have configured the automatic failover feature, see [Appendix B, “Setting Up Auto-Failover,” on page 91](#).

Upgrading Business Continuity Clustering for NetWare

3

Novell Business Continuity Clustering 1.0 supports only Novell® Cluster Services™ for NetWare®. This section covers two upgrade scenarios:

- ♦ Section 3.1, “Upgrading Business Continuity Clustering from 1.0 to 1.1 for NetWare,” on page 57
- ♦ Section 3.2, “Upgrading Business Continuity Clustering from 1.0 or 1.1 for NetWare to 1.1 for Linux,” on page 59

3.1 Upgrading Business Continuity Clustering from 1.0 to 1.1 for NetWare

- ♦ Section 3.1.1, “Upgrading NetWare,” on page 57
- ♦ Section 3.1.2, “Installing or Upgrading Identity Manager,” on page 58
- ♦ Section 3.1.3, “Installing Business Continuity Clustering 1.1,” on page 58
- ♦ Section 3.1.4, “Resetting BCC Administrator User Credentials,” on page 58
- ♦ Section 3.1.5, “Authorizing the BCC Administrator User,” on page 58
- ♦ Section 3.1.6, “Verifying SAN Scripts,” on page 59
- ♦ Section 3.1.7, “Deleting and Re-Creating the BCC-Specific Identity Manager Drivers,” on page 59

3.1.1 Upgrading NetWare

NetWare must be upgraded on each BCC cluster server to NetWare 6.5 SP5 or SP6 (same as OES 1 SP2 NetWare). NetWare 6.5 SP5 is the minimum requirement for Business Continuity Clustering 1.1 for NetWare. See “Upgrading to OES 1 NetWare” (<http://www.novell.com/documentation/oes/install-nw/data/hqwoj1yu.html#hqwoj1yu>) in the *OES NetWare Installation Guide* (http://www.novell.com/documentation/oes/install-nw/data/front_html.html) for more information on upgrading NetWare.

Also, see Section 2.1, “Requirements,” on page 17 for more information on what is required for Business Continuity Clustering 1.1 for NetWare.

In addition to upgrading NetWare, you must also apply the latest NetWare and Novell Cluster Services patches to the upgraded servers. See the [Business Continuity Clustering 1.1 Readme file](http://www.novell.com/documentation/bcc11/readme/data/readme11.html) (<http://www.novell.com/documentation/bcc11/readme/data/readme11.html>) for instructions on the necessary patches.

Performing a Rolling Cluster Upgrade

Performing a rolling upgrade to NetWare 6.5 SP5 (or to SP6) and applying the latest patches lets you keep your cluster up and running and lets your users continue to access the network while the upgrade is being performed.

During a rolling cluster upgrade, one server is upgraded to NetWare 6.5 SP5 (or to SP6) and the latest patches are applied while the other servers in the cluster continue running a previous support pack of NetWare 6.5. Then another server is upgraded to NetWare 6.5 SP5 (or SP6) with the latest patches, and then another, until all servers in the cluster have been upgraded to NetWare 6.5 SP5 (or SP6) with the latest patches.

After upgrading NetWare and applying the latest patches, reboot the server to automatically load Cluster Services software.

During the upgrade process, cluster pools, volumes, and resources fail over from the server being upgraded to other servers in the cluster. After a cluster server is upgraded and brought back online, the pools, volumes, and resources that failed over to other servers during the upgrade process fail back to the upgraded server.

3.1.2 Installing or Upgrading Identity Manager

You must upgrade to or install Identity Manager 2 Bundle Edition on one cluster server in each of the Novell Cluster Services clusters of your BCC. If you are upgrading to Identity Manager on a BCC server where DirXML[®] is installed, see “Upgrading” (<http://www.novell.com/documentation/dirxml20/admin/data/ampxjxi.html>) and “Common Installation Scenarios” (<http://www.novell.com/documentation/dirxml20/admin/data/brpgxw9.html#brpgxw9>) in the *Identity Manager 2.0.1 Administration Guide*.

If you are installing Identity Manager 2 Bundle Edition, see “Installing and Configuring Identity Manager” on page 20.

3.1.3 Installing Business Continuity Clustering 1.1

After upgrading NetWare and Identity Manager, you must install Business Continuity Clustering 1.1 on all cluster nodes that will be part of your BCC. See Section 2.2, “Installing Novell Business Continuity Clustering Software,” on page 22 for information on installing Business Continuity Clustering 1.1.

The Business Continuity Clustering 1.1 installation program automatically detects if Business Continuity Clustering 1.0 is installed and performs the necessary updates to convert 1.0 to 1.1. This includes searching eDirectory[™] for SAN scripts and updating those scripts to be SMI-S compliant.

3.1.4 Resetting BCC Administrator User Credentials

The BCC Administrator user credentials that were set for Business Continuity Clustering 1.0 do not work with Business Continuity Clustering 1.1. A fully distinguished eDirectory name (FDN) was required for Business Continuity Clustering 1.0, but Business Continuity Clustering 1.1 requires only the BCC administrator name. For instructions on resetting BCC Administrator user credentials, see Section 2.5.2, “Changing Cluster Peer Credentials,” on page 48.

3.1.5 Authorizing the BCC Administrator User

The BCC Administrator user must be a trustee of the Cluster objects in your BCC, and have at least read and write rights to the all attributes rights property.

- 1 Start your Internet browser and enter the URL for iManager.

The URL is `http://server_ip_address/nps/iManager.html`. Replace `server_ip_address` with the IP address or DNS name of the server that has iManager and the Identity Manager preconfigured templates for iManager installed.

- 2 Specify your username and password, specify the tree where you want to log in, then click *Login*.
- 3 In the left column, click *Rights*, then click the *Modify Trustees* link.
- 4 Specify the Cluster object name, or browse and select it, then click *OK*.
- 5 If the BCC Administrator user is not listed as a trustee, click the *Add Trustee* button, browse and select the User object, then click *OK*.
- 6 Click *Assigned Rights* for the BCC Administrator user, then ensure that the Read and Write check boxes are selected for the All Attributes Rights property.
- 7 Click *Done* to save your changes.
- 8 Repeat [Step 3](#) through [Step 7](#) for the other Cluster objects in your BCC.

3.1.6 Verifying SAN Scripts

The Business Continuity Clustering 1.1 installation program searches for and updates any SAN scripts that you created for Business Continuity Clustering 1.0. The updates are performed to make the SAN scripts SMI-S compliant. You should check all SAN scripts after installing Business Continuity Clustering 1.1 to ensure that they will perform the desired functions.

3.1.7 Deleting and Re-Creating the BCC-Specific Identity Manager Drivers

After completing the upgrade procedures in the above sections you must delete the BCC-specific Identity Manager drivers that were created when you installed and configured Business Continuity Clustering 1.0. This includes the cluster synchronization drivers, and if you configured User object synchronization, the User object synchronization driver. You must then re-create those drivers in order for them to work with Business Continuity Clustering 1.1. See [Section 2.4.1, “Configuring Identity Manager Drivers for the Business Continuity Cluster,”](#) on page 33.

During a BCC upgrade, Business Continuity Clustering 1.0 clusters are unable to communicate with Business Continuity Clustering 1.1 clusters. This condition exists temporarily until the upgrade has been completed. If an actual disaster were to occur during the upgrade, a Business Continuity Clustering 1.0 cluster can be failed over to a Business Continuity Clustering 1.1 cluster.

3.2 Upgrading Business Continuity Clustering from 1.0 or 1.1 for NetWare to 1.1 for Linux

To upgrade from Business Continuity Clustering 1.0 (NetWare only) to Business Continuity Clustering 1.1 for Linux, you must first upgrade all nodes in Business Continuity Clustering 1.0 clusters to Business Continuity Clustering 1.1 for NetWare. To do this, follow the instructions in [Section 3.1, “Upgrading Business Continuity Clustering from 1.0 to 1.1 for NetWare,”](#) on page 57.

IMPORTANT: All cluster nodes in every cluster in your BCC must be upgraded to Business Continuity Clustering 1.1 for NetWare before converting clusters to Novell Cluster Services for Linux.

After all nodes have been upgraded to Business Continuity Clustering 1.1 for NetWare, you can begin to convert them to Linux. On one cluster, upgrade NetWare cluster nodes to Linux by following the instructions in “[Converting a NetWare Cluster to Linux](http://www.novell.com/documentation/oes/cluster_admin_lx/data/bu1b1x8.html)” (http://www.novell.com/documentation/oes/cluster_admin_lx/data/bu1b1x8.html) in the *OES Novell Cluster Services 1.8.2 Administration Guide for Linux*.

Clusters containing NetWare and Linux servers are supported in a BCC only as a temporary means to convert a cluster from NetWare to Linux. Part of the temporary conversion state includes a restriction that only one mixed cluster can exist in your BCC. For example, Cluster A can have both NetWare and Linux nodes, but Cluster B cannot. All nodes in Cluster B must be either NetWare or Linux.

You must re-create the BCC-specific Identity Manager drivers after converting to Linux. See “[Configuring Identity Manager Drivers for the Business Continuity Cluster](#)” in the *Novell Business Continuity Clustering 1.1 for Linux Administration Guide*.

Normally, when converting a NetWare cluster to Linux, you need to run the `cluster convert` command after the entire cluster has been converted to Linux. When converting a BCC to Linux, do not run the `cluster convert` command until all clusters in the BCC have been upgraded and converted to Linux. See “[Finalizing the Cluster Conversion](http://www.novell.com/documentation/oes/cluster_admin_lx/data/bu1b1x8.html#buj98g9)” (http://www.novell.com/documentation/oes/cluster_admin_lx/data/bu1b1x8.html#buj98g9) in the *Novell Cluster Services 1.8.2 for Linux Administration Guide*.

The same restrictions that apply to migrating or failing over resources between nodes within a mixed cluster also apply to migrating or failing over resources between clusters in a mixed BCC. You can only migrate or fail over NSS pool/volume resources between clusters in a mixed BCC.

Troubleshooting Business Continuity Clustering 1.1

4

This section contains the following topics to help you troubleshoot Novell® Business Continuity Clustering 1.1.

- ◆ [Section 4.1, “Cluster Connection States,” on page 62](#)
- ◆ [Section 4.2, “Driver Ports,” on page 63](#)
- ◆ [Section 4.3, “Excluded Users,” on page 64](#)
- ◆ [Section 4.4, “Security Equivalent User,” on page 64](#)
- ◆ [Section 4.5, “Certificates,” on page 65](#)
- ◆ [Section 4.6, “Clusters Cannot Communicate,” on page 66](#)
- ◆ [Section 4.7, “BCC Startup Flags,” on page 66](#)
- ◆ [Section 4.8, “Problems With BCC Installation on NetWare,” on page 67](#)
- ◆ [Section 4.9, “Identity Manager Drivers for Cluster Synchronization Do Not Start,” on page 67](#)
- ◆ [Section 4.10, “Identity Manager Drivers Do Not Synchronize Objects from One Cluster to Another,” on page 68](#)
- ◆ [Section 4.11, “Tracing Identity Manager Communications,” on page 68](#)
- ◆ [Section 4.12, “Peer Cluster Communication Not Working,” on page 69](#)
- ◆ [Section 4.13, “Administration of Peer Clusters Not Functional,” on page 69](#)
- ◆ [Section 4.14, “Resource Does Not Migrate to Another Cluster,” on page 70](#)
- ◆ [Section 4.15, “Resource Cannot Be Brought Online,” on page 70](#)
- ◆ [Section 4.16, “Dumping Syslog on NetWare,” on page 70](#)
- ◆ [Section 4.17, “Slow Failovers,” on page 70](#)
- ◆ [Section 4.18, “Resource Script Search and Replace Functions Do Not Work,” on page 71](#)
- ◆ [Section 4.19, “Virtual NCP Server IP Addresses Won’t Change,” on page 71](#)
- ◆ [Section 4.20, “IP Address, Virtual Server DN, or Pool Name Does Not Appear on the iManager Cluster Configuration Page,” on page 71](#)
- ◆ [Section 4.21, “Blank Error String iManager Error Appears While Bringing a Resource Online,” on page 72](#)
- ◆ [Section 4.22, “Best Practices,” on page 72](#)
- ◆ [Section 4.23, “Mapping Drives in Login Scripts,” on page 73](#)
- ◆ [Section 4.24, “Mapping Drives to Home Directories by Using the %HOME_DIRECTORY Variable,” on page 73](#)
- ◆ [Section 4.25, “BCC Error Codes,” on page 74](#)

4.1 Cluster Connection States

The following table identifies the different cluster connection states and gives descriptions and possible actions for each state.

Table 4-1 BCC Connection States

BCC Connection State	Number	Description	Possible Actions
Normal	0	The connections between clusters are functioning normally.	None required.
Authenticating	1	BCC is in the process of authenticating to a peer cluster.	Wait until the authentication process is finished.
Invalid Credentials	2	You entered the wrong username or password for the selected peer cluster.	Enter the correct username and password that this cluster will use to connect to the selected peer cluster.
Cannot Connect	3	This cluster cannot connect to the selected peer cluster.	<p>Ping the peer cluster to see if it is up and reachable.</p> <p>Ensure that BCC is running on the peer cluster and that Novell Cluster Services™ is running on the servers in the peer cluster.</p> <p>Ensure that OpenWBEM is running on the peer cluster.</p> <p>Ensure that a firewall is not preventing access on OpenWBEM ports 5988 and 5989.</p> <p>Ensure that the Admin file system is running. To do this, see if the <code>_admin</code> volume is mounted on NetWare, or on Linux enter <code>etc/init.d/adminfs status</code>.</p>
Not Authorized	4	The connected user does not have sufficient rights for permissions.	Assign the appropriate trustee rights to the user who will manage your BCC. For information, see "Assigning Trustee Rights for the BCC Administrator User to the Cluster Objects" on page 24.
Connection Unknown	5	The connection state between clusters is unknown.	This connection state might be caused by any number of problems, including a severed cable or link problems between geographic sites.

The connection state numbers are recorded in a log file that you can use to view connection and status changes for BCC.

The default path to the log file on Linux is `/var/log/messages`. The administrator might have changed this path from the default. Search for `BCCD` to view `BCC` related messages and entries in the log file.

To view the log file on NetWare®:

- 1 At the NetWare server console, enter `log +copy syslog`.
- 2 Using an editor, open the file that is referenced in the message that appears.
You can get additional information on how to use the log file by entering `help log` at the NetWare server console.

4.2 Driver Ports

If your Identity Manager driver or drivers won't start, check for a port number conflict. Identity Manager driver port numbers must not be the same as other driver port numbers in the cluster or ports being used by other services such as Apache.

To check driver port numbers:

- 1 Start your Internet browser and enter the URL for iManager.
The URL is `http://server_ip_address/nps/iManager.html`. Replace `server_ip_address` with the IP address or DNS name of the server that has iManager and the Identity Manager preconfigured templates for iManager installed.
- 2 Specify your username and password, specify the tree where you want to log in, then click *Login*.
- 3 In the left column, click *DirXML*, then click the *DirXML Overview* link.
DirXML is called Identity Manager in the latest releases.
- 4 Select *Search Entire Tree*, then click *Search*.
- 5 Select the driver you want to check by clicking the red *Cluster Sync* icon or the blue *User Sync* icon.
- 6 Click the red or blue icon again, then click the *DirXML* tab (if it is not already selected).
- 7 In the *Authentication context* field, view and if necessary change the port numbers next to the IP address.

For example, the *Authentication context* field might contain a value similar to `10.1.1.12:2003:2003`. In this example, the first port number (2003) is the port number for the corresponding Identity Manager driver on the cluster this cluster is synchronizing with. The second port number (2003) is the port number for the Identity Manager driver on this cluster.

These port numbers should be the same, but should not be the same as the port numbers for other Identity Manager drivers on either this or the remote cluster.

- 8 If you change the port numbers, restart the driver by clicking the upper right corner of the *Cluster Sync* or *User Sync* icon (whichever you have chosen), then click *Restart driver*.
- 9 If you changed the port number in [Step 7](#) above, change the port numbers to be the same for the corresponding driver in the other cluster.

You can do this by repeating [Step 1](#) through [Step 8](#) for the Identity Manager driver on the other cluster.

4.3 Excluded Users

If certain users do not synchronize between clusters, it is possible that those users are included in the excluded users list.

NOTE: The eDirectory™ Admin user should never be synchronized between clusters.

To see the excluded users list:

- 1 Start your Internet browser and enter the URL for iManager.
The URL is `http://server_ip_address/nps/iManager.html`. Replace *server_ip_address* with the IP address or DNS name of the server that has iManager and the Identity Manager preconfigured templates for iManager installed.
- 2 Specify your username and password, specify the tree where you want to log in, then click *Login*.
- 3 In the left column, click *DirXML*, then click the *DirXML Overview* link.
DirXML is called Identity Manager in the latest releases.
- 4 Select *Search Entire Tree*, then click *Search*.
- 5 Select the user synchronization driver you want to check by clicking the blue *User Sync* icon.
This is not necessary for the cluster synchronization driver.
- 6 Click the blue icon again, then click the *DirXML* tab if it is not already selected.
- 7 Click *Excluded Users*, and view, add, or remove users as desired.

4.4 Security Equivalent User

If resources or peers don't appear in other clusters in your BCC, it is possible that either a cluster or user synchronization driver is not security equivalent to a user with administrative rights to the cluster.

NOTE: Rather than using the eDirectory Admin user to administer your BCC, you should consider creating another user with sufficient rights to the appropriate contexts in your eDirectory tree to manage your BCC.

The IDM Driver object must have sufficient rights to create, modify, and delete objects and attributes in the following containers:

- ♦ The Identity Manager driver set container.
- ♦ The container where the Cluster object resides.
- ♦ The container where the Server objects reside.

If server objects reside in multiple containers, this must be a container high enough in the tree to be above all containers that contain server objects.

Best practice is to have all server objects in one container.

- ♦ The container where the cluster pool and volume objects are placed when they are synchronized to this cluster. This container is sometimes referred to as the landing zone. The NCP™ server objects for the virtual server of a business-continuity-enabled resource are also placed in the landing zone.

To make the Cluster Resource Synchronization driver or User Object Synchronization driver security equivalent to a user with administrative rights:

- 1 Start your Internet browser and enter the URL for iManager.
The URL is `http://server_ip_address/nps/iManager.html`. Replace `server_ip_address` with the IP address or DNS name of the server that has iManager and the Identity Manager preconfigured templates for iManager installed.
- 2 Specify your username and password, specify the tree where you want to log in, then click *Login*.
- 3 In the left column, click *DirXML*, then click the *DirXML Overview* link.
DirXML is called Identity Manager in the latest releases.
- 4 Choose *Search Entire Tree*, then click *Search*.
- 5 Select the driver you want to check by clicking the red *Cluster Sync* icon or the blue *User Sync* icon.
- 6 Click the red or blue icon again, then click the *DirXML* tab if it is not already selected.
- 7 Click *Security Equals*, and view or add a security equivalent user as needed.
- 8 Repeat [Step 5](#) through [Step 7](#) for the other drivers in your BCC.

You must also ensure that the BCC Administrator user has Read, Write, Create, Erase, Modify, and File Scan access rights to the `sys:/tmp` directory on every node in your NetWare clusters.

For Linux, ensure that the BCC Administrator user is a LUM-enabled user. To LUM-enable a user, see “[Managing User and Group Objects in eDirectory](http://www.novell.com/documentation/oes/lumadgd/data/aeucqum.html)” (<http://www.novell.com/documentation/oes/lumadgd/data/aeucqum.html>) in the *Novell Linux User Management Technology Guide*.

NOTE: For NetWare, if you are concerned about denial of service attacks with the BCC Administrator user, you can set a quota of 5 MB for that user. This can prevent the BCC Administrator user from filling the `sys:` volume by copying an excessive number of files to the `sys:/tmp` directory

4.5 Certificates

If SSL certificates are not present or have not been created, Identity Manager drivers might not start or function properly. Novell recommends using SSL certificates for encryption and security.

NOTE: You should create or use a different certificate than the default (dummy) certificate (BCC Cluster Sync KMO) that is included with BCC.

See “[Creating SSL Certificates](#)” on [page 35](#) for more information on creating SSL certificates for BCC.

4.6 Clusters Cannot Communicate

If the clusters in your BCC cannot communicate with each other, it is possible that the User object you are using to administer your BCC does not have sufficient rights to the Cluster objects for each cluster. To resolve this problem, ensure that the BCC Administrator user is a trustee of the Cluster objects and has at least Read and Write rights to the All Attributes Rights property.

- 1 Start your Internet browser and enter the URL for iManager.
The URL is `http://server_ip_address/nps/iManager.html`. Replace *server_ip_address* with the IP address or DNS name of the server that has iManager and the Identity Manager preconfigured templates for iManager installed.
- 2 Specify your username and password, specify the tree where you want to log in, then click *Login*.
- 3 In the left column, click *Rights*, then click the *Modify Trustees* link.
- 4 Specify the Cluster object name, or browse and select it, then click *OK*.
- 5 If the BCC Administrator user is not listed as a trustee, click the *Add Trustee* button, browse and select the User object, then click *OK*.
- 6 Click *Assigned Rights* for the BCC Administrator user, then ensure that the *Read* and *Write* check boxes are selected for the *All Attributes Rights* property.
- 7 Click *Done* to save your changes.
- 8 Repeat [Step 3](#) through [Step 7](#) for the other Cluster objects in your BCC.

4.7 BCC Startup Flags

There are three optional flags that can be used by BCC during startup. [Table 4-2](#) lists the flags and provides a description of each flag.

Table 4-2 *Optional Startup Flags*

Startup Flag	Description
d	On Linux, this flag keeps the bccd from forking (keeps the process in foreground) and log messages are printed to the running terminal screen (stdout) along with the normal syslog. This flag is not used on NetWare.
v	On both Linux and NetWare, this flag turns on more verbose logging.
t	On both Linux and NetWare, this flag turns on tracing. With tracing turned on, certain sections of code that fail will report a message containing the condition that failed along with a file and line number in the code indicating where the condition failed. This is helpful for reporting problems to Novell Support.

4.7.1 Using BCC Startup Flags on NetWare

On NetWare, edit the `sys:\system\ldbcc.ncf` file and change the `load bccd.nlm` line to `load bccd.nlm -flags`. Replace *flags* with any combination of v and/or t. This could include v, vt, t, or tv.

4.7.2 Using BCC Startup Flags on Linux

On Linux, there are two options:

- ♦ To use the *v* and *t* flags, edit the `/etc/init.d/novell-bcc` file and change the `NOVELL_BCCD_ARGS=` line to `NOVELL_BCCD_ARGS=-flags`. Replace *flags* with any combination of *v* and/or *t*. This could include *v*, *vt*, *t*, or *tv*.

Do not use the *d* flag with this option.

- ♦ Stop BCC by entering `rcnovell-bccd stop` at the server console, then restart it by entering `/opt/novell/bcc/sbin/bccd -flags`. Replace *flags* with any combination of *v*, *t*, and/or *d*.

4.8 Problems With BCC Installation on NetWare

Occasional problems might exist when installing BCC software on NetWare cluster servers. For example, you might experience problems expanding an Organizational Unit (OU) when browsing the eDirectory tree during the BCC installation.

To resolve this and similar problems, rename the `c:\program files\common files\novell` directory on the Windows machine where the installation is being run and restart the Business Continuity Clustering 1.1 installation program.

4.9 Identity Manager Drivers for Cluster Synchronization Do Not Start

If the Identity Manager drivers for cluster synchronization do not start, the problem might be caused by one of the following conditions:

- ♦ A certificate has not been created. For information, see [“Creating SSL Certificates” on page 35](#).
- ♦ The ports used by the driver are not unique and available.

Each eDirectory driver must listen on a different port number. To specify the port number, access the driver properties in iManager and specify the appropriate port number in the IP address field. See [Section 2.4.1, “Configuring Identity Manager Drivers for the Business Continuity Cluster,” on page 33](#) for more information.

The format for specifying the port number in the IP address field is *remote IP:remote port:local port*. For example, you could specify something similar to `10.1.1.1:2001:2001`. If it is not being used for other drivers, port 2001 can be used for the User object driver and port 2002 for the Cluster object driver.

- ♦ The driver has been disabled.

Click the red icon for the driver on the DirXML Driver Overview page. You can enable the driver by using the radio buttons in the Driver Startup section of the page that displays.

Selecting the Auto Start option is recommended.

- ♦ Unknown communications problems.

See [Section 4.11, “Tracing Identity Manager Communications,” on page 68](#).

- ◆ -670 errors in the DSTrace logs. See [TID # 10090395 \(http://support.novell.com/docs/Tids/Solutions/10090395.html\)](http://support.novell.com/docs/Tids/Solutions/10090395.html)

This is commonly caused by `rconag6.nlm` loading before SAS, which causes problems when Identity Manager tries to load. The load order is sometimes changed by the installation of a product that changes the order of the lines within the `autoexec.ncf` file.

4.10 Identity Manager Drivers Do Not Synchronize Objects from One Cluster to Another

If objects are not synchronizing between clusters, the problem might be caused by one of the following conditions:

- ◆ The drivers are not running.
- ◆ A driver is not security equivalent to an object with the necessary rights in the tree.
- ◆ You have underscores and spaces in object names.
eDirectory interprets underscores and spaces as the same character. For example, if you have a cluster template named `iFolder Server` and you try to synchronize a resource named `iFolder_Server`, the synchronization fails. This is because the underscore character is mapped to a space. eDirectory returns an error that the entry already exists.
- ◆ The eDirectory partition on the Identity Manager node is incorrect.
This partition must contain the cluster container, the DriverSet, the Landing Zone OU, and the server containers (Virtual NCP™ Servers, Volumes, and Pools).
- ◆ The drivers are not communicating on the same port.
For example, if the driver on Cluster A is listening on port 2002, the driver on Cluster B must bind to port 2002 on Cluster A in order for the driver communication to work properly.
The format for specifying the port number in the IP address field is *remote IP:remote port:local port*. For example, you could specify something similar to `10.1.1.1:2001:2001`. If it is not being used for other drivers, port 2001 can be used for the User object driver and port 2002 for the Cluster object driver.
- ◆ See [Tracing Identity Manager Communications](#) below.

4.11 Tracing Identity Manager Communications

DSTrace is used to trace Identity Manager communications. In a BCC, it is generally best to trace both sides of the communication channel (both drivers).

To trace the communications for the BCC-specific Identity Manager drivers on a NetWare BCC:

- 1 Modify two attributes on both DriverSet objects.
 - 1a Start your Internet browser and enter the URL for iManager.
The URL is `http://server_ip_address/nps/iManager.html`. Replace *server_ip_address* with the IP address or DNS name of the server that has iManager and the Identity Manager preconfigured templates for iManager installed.
 - 1b Specify your username and password, specify the tree where you want to log in, then click *Login*.

- 1c** Click the *View Objects* button at the top of the iManager page.
- 1d** In the left column, browse to and right-click the desired DriverSet object, then select *Modify Object*.
- 1e** Click the *General* tab, and in the list of valued attributes, click *DirXML-DriverTraceLevel*, then click *Edit*.
- 1f** Ensure that the Trace Level is set to 4, then click *OK*.
- 1g** Repeat [Step 1e](#) and [Step 1f](#) for the DirXML-XSLTraceLevel attribute, also setting the trace level to 4.
- 1h** Repeat [Step 1d](#) through [Step 1g](#) for the other driver sets you want to trace.
- 2** At the NetWare server console, load DSTrace by entering `dstrace`.
- 3** Configure DSTrace by entering `dstrace inline -all +dvrs +dxml` at the NetWare server console.
- 4** Enable DSTrace by again entering `dstrace` at the NetWare server console.
- 5** Run the desired actions for the information you want traced.
- 6** Disable DSTrace by entering `dstrace off` at the NetWare server console.

The trace file is located at `sys:/system/dstrace.log`. You might want to delete this file before starting a trace so the events logged in the file are specific to the actions you are tracing.

4.12 Peer Cluster Communication Not Working

If BCC communication between peer clusters is not functioning, the problem might be caused by one of the following conditions:

- ♦ The credentials for the remote cluster have not been set.

You cannot use iManager on a server in one tree to set credentials for a BCC cluster in another tree. This is because BCC and iManager use the tree key to encrypt the credentials. Setting credentials by using iManager in a different tree uses an invalid tree encryption.

- ♦ LIBC has not been updated. See [LIBC Update NetWare 6.5 SP6 9.00.05 \(Technical Information Document # 5003460\)](http://support.novell.com/docs/Readmes/InfoDocument/patchbuilder/readme_5003460.html) (http://support.novell.com/docs/Readmes/InfoDocument/patchbuilder/readme_5003460.html).
- ♦ A firewall is blocking port 5988 or 5989 (CIM).

4.13 Administration of Peer Clusters Not Functional

This problem is normally caused by the BCC Administrator user not having file system rights to the cluster administration files. See [“Verifying BCC Administrator User Trustee Rights and Credentials” on page 43](#).

4.14 Resource Does Not Migrate to Another Cluster

If you cannot migrate a resource from one cluster to another, the problem might be caused by one of the following conditions:

- ♦ The resource has not been BCC-enabled.
- ♦ Remote clusters cannot communicate.

See [Section 4.12, “Peer Cluster Communication Not Working,”](#) on page 69.

- ♦ Syslog shows error 1019 (NSMI error).

There could be a partial script in `sys:/tmp`. The scripts are named `NSMIT-#####.tmp`. If there is a partial script, NSMI is experiencing an error and not communicating with the SAN to make disks visible. One reason for this is that the script might have a single `%` character in it that needs to be an escape (`%%` instead of `%`). For example, hashes in Perl need to have escape characters.

4.15 Resource Cannot Be Brought Online

If you cannot bring a BCC-enabled resource online, it is possible the resource might be set as secondary. If the `NCS:BCC State` attribute is equal to 1, the resource is set to secondary and cannot be brought online.

On the resource object, change the `NCS:BCC State` attribute to 0 to set the resource to the primary state. Also, increment the `NCS:Revision` attribute one number so that Novell Cluster Services™ recognizes that the resource properties have been updated. See [Step 1 on page 68](#) for an example of how to modify object attributes.

4.16 Dumping Syslog on NetWare

The command `log +dump syslog` sends the output of the syslog to the console screen. This command has limited use because only the last few entries of the log can be viewed.

You can use the `log +copy syslog` command to copy the syslog to a file and then use the NetWare Edit utility to view it. The output file `syslog` is copied to is displayed after the command is executed.

Enter `log help` at the NetWare server console to get additional information on `syslog`.

4.17 Slow Failovers

Failovers might be slow because the resource is slow to go offline on the source cluster. This can happen if the failover occurs during a time when file I/O is taking place on the cluster.

To resolve this problem, edit the resource unload script and change the `NUDP DEL name ip` line to `NUDP ODEL name ip`. Unlike the `DEL` command, the `ODEL` command does not wait for all NCP connections to close. This makes it much faster.

NOTE: The cluster resource must be brought offline and then back online for changes to the unload script to take effect. Client data might be lost if clients are accessing the resource when it is brought offline.

4.18 Resource Script Search and Replace Functions Do Not Work

If resource script search and replace functions are not working, the problem might be caused by one of the following conditions:

- ♦ You did not click the *Apply* button on the Properties page. Clicking *OK* when entering the scripts does not apply the changes to the directory.
- ♦ You added the search and replace values to the resource instead of to the cluster.
The search and replace values to apply to a specific resource instead of all resources in the cluster.
- ♦ If you are testing search and replace functionality, you might have made the changes too rapidly.
Identity Manager merges all changes into one, so if you quickly add a change and then delete it, Identity Manager might view it as no change. You should make a change and verify that the change has synchronized with the other cluster before deleting it.

4.19 Virtual NCP Server IP Addresses Won't Change

If the IP address for a virtual (NCP) server does not change properly, the problem may be caused by one of the following conditions:

- ♦ The IP address has been changed only on the load and unload script pages.
You must also change the IP address on the protocols page for the virtual server. Changing the IP address on the protocols page causes the load and unload scripts to automatically update.
- ♦ The virtual server has an extra IP address.
On NetWare, you can use the General tab in ConsoleOne® to view the IP addresses for the virtual server. If there are extra IP addresses, do the following:
 1. In ConsoleOne, click *Page Options* and disable the *General* tab.
 2. Click *Cancel* to exit the properties dialog box.
 3. Access the properties dialog box again.
 4. Click the *Other* tab and delete the extra IP addresses.
The attribute is Network Address. Do not delete the entire attribute, just the values for the extra IP addresses.
 5. Click *Page Options* and enable the *General* tab.
 6. Click *Apply* to save your changes.

4.20 IP Address, Virtual Server DN, or Pool Name Does Not Appear on the iManager Cluster Configuration Page

You might see a DSML read error if you select properties for a Cluster object and then click the BCC tab.

The eDirectory pointers for the cluster resource are either missing or are invalid. The following list shows the required attributes. The format for the list is:

Object in the directory (Object Class Name)

Attribute Name -->The object in the directory the attribute points to

Attribute Name -->The object in the directory the attribute points to

Clustered Volume (Object Class “NCS:Volume Resource”)

NCS:NCP Server -->Virtual NCP Servers

NCS:Volumes-->All Volumes

Virtual NCP Server (Object Class “NCP Server”)

Resource-->Cluster Resource

NCS:NetWare Cluster-->Cluster Object

NCS:Volumes-->All Volumes

Volume (Object Class “Volume”)

nssfsPool-->Pool Object

Host Server-->Virtual NCP Server

Pool (Object Class “nssfsPool”)

Host Server-->Virtual NCP Server

4.21 Blank Error String iManager Error Appears While Bringing a Resource Online

If you get an error in iManager with a blank error string (no text appears with the error message) while attempting to bring a resource online, it is possible that Novell Cluster Services views the resource as secondary even though BCC has changed the resource to primary and iManager shows the resource as primary.

To resolve this problem, make a change to the cluster properties to cause the NCS:Revision attribute to increment. You could add a comment to the resource load script to cause this to happen.

4.22 Best Practices

The following practices help you avoid potential problems with your BCC:

- ♦ IP address changes should always be made on the Protocols page of the iManager cluster snap-in, not in load and unload scripts.

This is the only way to change the IP address on the virtual NCP server object in eDirectory.

- ♦ Ensure that eDirectory and your clusters are stable before implementing BCC.
- ♦ Engage Novell Consulting.
- ♦ Engage a consulting group from your SAN vendor.

- ♦ The cluster node that hosts the Identity Manager driver should have a read/write replica with the following containers in the replica (filtered replicas were not supported in Business Continuity Clustering 1.0):
 - ♦ Driver set container
 - ♦ Cluster container
 - ♦ (Parent) container where the servers reside
 - ♦ Landing zone container
- ♦ Ensure that you have full read/write replicas of the entire tree at each data center.

4.23 Mapping Drives in Login Scripts

Consider the following when mapping drives in login scripts in a BCC:

- ♦ Using an FDN (such as `map s:=BCCP_Cluster_HOMES.servers.:shared`) to a cluster-enabled volume has been tested and does not work.

When the resource fails over to the secondary cluster, the DN does not resolve to a server/volume that is online. This causes the `map` command to fail.

- ♦ Using the `SLP Server Name/VOL:shared` syntax has been tested and works.
SLP Server Name is the name being advertised in SLP as specified in the resource load script. This method requires a client reboot.
- ♦ See [TID 10057730 \(http://support.novell.com/docs/Tids/Solutions/10057730.html\)](http://support.novell.com/docs/Tids/Solutions/10057730.html) for information on modifying the server cache Time To Live (TTL) value on the Novell Client™.

4.24 Mapping Drives to Home Directories by Using the %HOME_DIRECTORY Variable

Consider the following when mapping drives in login scripts in a BCC:

- ♦ Using the `%HOME_DIRECTORY` variable (such as `map u:=%HOME_DIRECTORY`) has been tested and does not work.

When you fail the resource over to the secondary cluster, the `%HOME_DIRECTORY` variable still resolves to the old volume object, and the `map` command fails.

- ♦ Using a temporary environment variable has been tested and does not work.

For example:

```
set FOO=%HOME_DIRECTORY
MAP u:=%FOO
```

- ♦ Using a false volume object along with ICE and LDIF has been tested and works.
 - ♦ Create a new volume object that references the real volume object.
The Host Server attribute must point to the virtual NCP server in the primary cluster, and the Host Resource Name attribute must specify the name of the volume. This new volume object can be referred to as a volume reference.
 - ♦ All User objects must be modified to have their Home Directory attribute reference the new volume object (volume reference).
 - ♦ Use LDIF and ICE in the NSMI script (SAN Array Mapping Information) area.

This script modifies the new volume reference object and updates the Host Server attribute to point to the virtual NCP server in the secondary cluster.

NOTE: Using LDIF/ICE prevents you from using the NSMI script to control the SAN. If you want to use LDIF/ICE and the NSMI script, you must have two NCF files: one for the SAN, and one for LDIF/ICE. The NSMI script must then call each NCF file separately.

See [TID 10057730](http://support.novell.com/docs/Tids/Solutions/10057730.html) (<http://support.novell.com/docs/Tids/Solutions/10057730.html>) for information on modifying the server cache Time To Live (TTL) value on the Novell Client.

A sample NSMI script is included below:

```
#!ICE -b -D LDAP -d cn=root,ou=servers,o=lab -w novell -S LDIF -f
#@ -s0 -w20
version: 1
dn: cn=HOMES_REF, ou=servers,o=lab
changetype: modify
replace: hostServer
hostServer:
cn=BCC_CLUSTER_HOMES_SERVER,ou=From_BCCP,ou=servers,o=lab
```

The first line in the sample script instructs NSMI to run the ICE utility.

- ♦ The -b parameter automatically closes the ICE window.
- ♦ The -d parameter is the administrator DN that is used to modify eDirectory.
- ♦ The -w parameter is the password.
- ♦ There must be a trailing space after the -f parameter.

The second line in the sample script includes NSMI-specific options.

- ♦ -s0 causes NSMI to not wait for a signal file.
- ♦ -w20 causes NSMI to wait 20 seconds before proceeding

Failure to add the wait causes the temporary LDIF file to be deleted before ICE can read it. This causes ICE to fail.

4.25 BCC Error Codes

The following table lists the different BCC error codes by number and gives a brief description for each error code.

Table 4-3 BCC Error Codes and Messages

Error Code Number	Message
1000	Unknown error.
1001	Received XML is invalid.
1002	The object pointers in eDirectory for the given cluster resource are invalid.
1003	The referenced object is not a valid NCS/BCC object.

Error Code Number	Message
1004	The referenced cluster resource is in an invalid state.
1005	The specified resource or cluster is not enabled for Business Continuity.
1006	An invalid parameter was passed to the BCC API.
1007	Attempt to allocate memory failed.
1008	Attempt to communicate with the BCC VFS system failed.
1009	The size of the specified buffer is not large enough.
1010	Error performing a DSML read.
1011	Error performing a DSML modify.
1012	Operation not supported
1013	Error obtaining lock on synchronization object
1014	Invalid credentials
1015	Error returned from the NICI API
1016	Cannot find peer cluster data
1017	Invalid BCC API version
1018	Could not find a pool for the specified cluster resource
1019	Error managing the SAN via the Novell SAN Management Interface
1020	CIM Client error
1021	Error creating a system resource (mutex, semaphore, etc.)
1022	File IO error
1023	No Data
1024	Not a member of cluster
1025	Invalid token in script
1026	Invalid or unknown cluster
1027	The NSMI script is too long. It must be less than 64 KB.
1028	The cluster-enabled pool resource does not contain a volume.
1029	An operation has timed out.
1030	The specified resource is already busy.

The error code numbers are recorded in a log file that you can use to view status changes for BCC.

The path to the log file on Linux is `/var/log/messages`. You can search for `BCCD` to view BCC related messages and entries in the log file.

To view the log file on NetWare:

- 1 At the NetWare server console, enter `log +copy syslog`.

2 Open the file that is referenced in the message that appears.

You can get additional information on how to use the log file by entering `help log` at the NetWare server console.

With the release of NetWare® 6.5, Novell® has enhanced the TCP/IP stack to support virtual IP addresses. This new feature is another high-availability offering that enables administrators to easily manage the name-to-IP address associations of business services. It complements the existing load balancing and fault tolerance features of the TCP/IP stack and enhances the availability of servers that reside on multiple subnets.

A virtual IP address is an IP address that is bound to a virtual Network Interface Card (NIC) and is driven by a new virtual driver named `vnic.lan`. As the name suggests, this virtual NIC is a purely virtual entity that has no physical hardware counterpart. A virtual NIC can be thought of as a conventional TCP/IP loopback interface with added external visibility. Virtual IP addresses can also be thought of as conventional loopback addresses with the 127.0.0.0 IP network constraint relaxed. A server with a virtual NIC and a virtual IP address acts as an interface to a virtual internal IP network that contains the server as the one and only host.

Regardless of their virtual nature, virtual IP addresses and virtual NICs behave like physical IP addresses and physical NICs, and they are similarly configured by using either the INETCFG server-based utility or the Novell Remote Manager (NRM) Web-based utility.

- ♦ [Section 5.1, “Virtual IP Address Definitions and Characteristics,” on page 77](#)
- ♦ [Section 5.2, “Virtual IP Address Benefits,” on page 78](#)
- ♦ [Section 5.3, “Other Added Features,” on page 81](#)
- ♦ [Section 5.4, “Reducing the Consumption of Additional IP Addresses,” on page 82](#)
- ♦ [Section 5.5, “Configuring Virtual IP Addresses,” on page 83](#)

5.1 Virtual IP Address Definitions and Characteristics

- ♦ [Section 5.1.1, “Definitions,” on page 77](#)
- ♦ [Section 5.1.2, “Characteristics,” on page 78](#)

5.1.1 Definitions

Virtual driver: The `vnic.lan` driver provided by Novell.

Virtual board (NIC): Any board configured to use the virtual driver.

Virtual IP address: Any IP address that is bound to a virtual board.

Virtual IP network: The IP network that the virtual IP address is a part of. In practical terms, this is defined by the virtual IP address together with the IP network mask that it is configured with.

Host mask: The IP network mask consisting of all 1s - `FF.FF.FF.FF` (255.255.255.255).

Physical IP address: Any IP address that is not a virtual IP address. In practical terms, it is an IP address that is configured over a physical hardware NIC.

Physical IP network: An IP network that a physical IP address is a part of. In practical terms, a physical IP network identifies a logical IP network that is configured over a physical hardware wire.

5.1.2 Characteristics

Virtual IP addresses are unique in that they are bound to a virtual “ether” medium instead of to a “physical” network medium such as Ethernet or token ring. In other words, the virtual IP address space is exclusive from the physical IP address space. As a result, virtual IP network numbers need to be different from physical IP network numbers. However, this mutual exclusivity of the IP address space for the physical and virtual networks doesn’t preclude the possibility of configuring multiple virtual IP networks in a single network domain.

5.2 Virtual IP Address Benefits

In spite of their simplicity, virtual IP addresses offer two main advantages over their physical counterparts:

- ♦ [Section 5.2.1, “High Availability,” on page 78](#)
- ♦ [Section 5.2.2, “Unlimited Mobility,” on page 81](#)

These advantages exist because virtual IP addresses are purely virtual and are not bound to a physical network wire.

5.2.1 High Availability

If a virtual IP address is defined on a multihomed server with more than one physical NIC, a virtual IP address is a highly reachable IP address on the server when compared to any of the physical IP addresses. This is especially true in the event of server NIC failures. This assumes that the server is running a routing protocol and is advertising its “internal” virtual IP network—which only it knows about and can reach—to other network nodes.

Physical IP addresses might not be reachable because:

- ♦ TCP/IP protocols use link-based (network-based) addressing to identify network nodes. As a result, the routing protocols preferentially deliver a packet to the server through the network that the target IP address is part of.
- ♦ Dynamic routing protocols are extremely resilient to intermediate link and router failures, but they do not adapt well to failures of links at the last hop that ultimately delivers a packet to its destination.

This is because the last hop link is typically a stub link that does not carry any routing heartbeats. Therefore, if one of the physical cards in a server fails, the server can become inaccessible as well as any service that it hosts on the corresponding physical IP address. This can occur in spite of the fact that the server is still up and running and can be reached through the other network card.

The virtual IP address feature circumvents this problem by creating a virtual IP network different from any of the existing physical IP networks. As a result, any packet that is destined for the virtual IP address is forced to use a virtual link as its last hop link. Because it is purely virtual, this last hop link can be expected to always be up. Also, because all other real links are forcibly made to act as intermediate links, their failures are easily worked around by the dynamic routing protocols.

The following figure illustrates a multihomed server with all nodes running a dynamic routing protocol.

Figure 5-1 Multihomed Server Running a Dynamic Routing Protocol

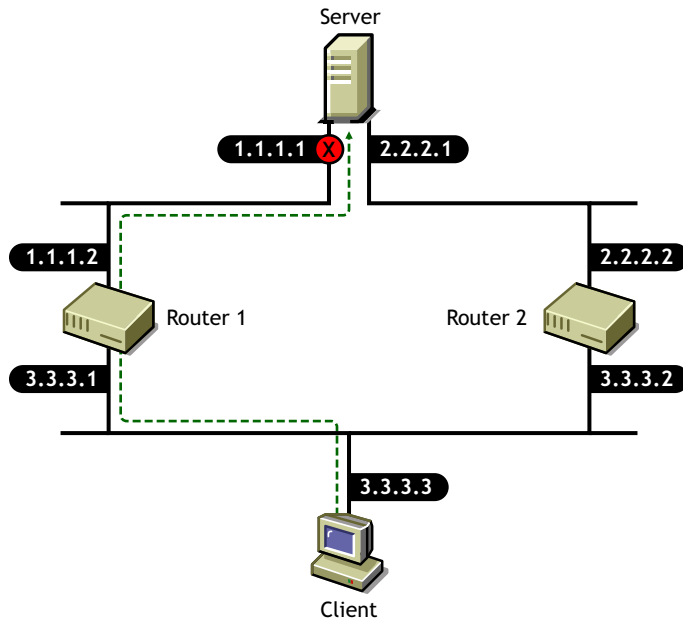

In this network, the server is a multihomed server hosting a critical network service. For simplicity, assume that all nodes are running some dynamic routing protocol.

If the client attempts to communicate with the server with the 1.1.1.1 IP address, it tries to reach the server through the nearest router, which is Router 1. If the 1.1.1.1 interface were to fail, Router 1 would continue to advertise reachability to the 1.0.0.0/FF.0.0.0 network and the client would continue to forward packets to Router 1. Being undeliverable, these packets would ultimately be dropped by Router 1. Therefore, in spite of the fact that the service is still up and running and can be reached through the other active interface, it is rendered unreachable. In this scenario, a recovery would involve the ability of the client application to retry the alternate IP address 2.2.2.1 returned by the name server.

Now consider the same scenario but with the server configured with a virtual IP address and the client communicating with the virtual IP address instead of one of the server's real IP addresses, as shown in the following figure.

Figure 5-2 Multihomed Server Using Virtual IP Addresses

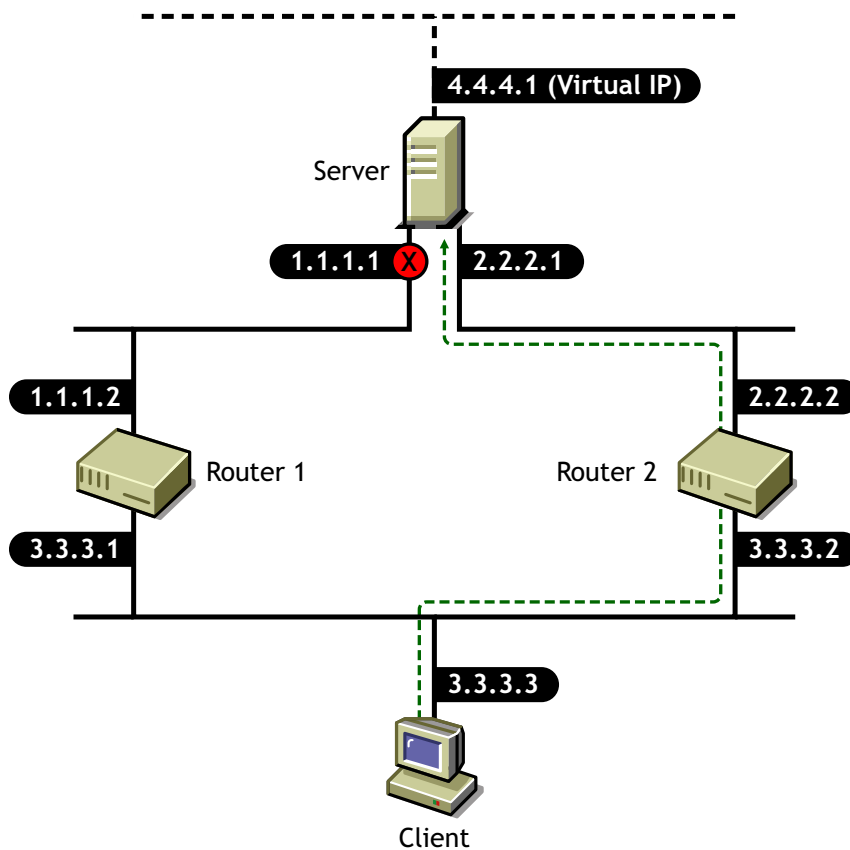

In this configuration, if the 1.1.1.1 interface were to fail, the client would ultimately learn the new route through Router 2 and would correctly forward packets to Router 2 instead of Router 1. Thus, despite physical interface failures, a virtual IP address on a multihomed server acts as an always-reachable IP address for the server.

Generally speaking, if a connection between two machines is established by using a virtual IP address as the end-point address at either end, the connection is resilient to interface failures at either end.

There are two important side effects that directly follow from the highly reachable nature of virtual IP addresses:

- ♦ They completely and uniquely identify a multihomed server

A multihomed server with a virtual IP address no longer needs to carry multiple DNS entries for its name in the naming system.

- ♦ They significantly enhance the LAN redundancy inherent in a multihomed server

If one of the subnets that a server interfaces to fails completely or is taken out of service for maintenance, the routing protocols reroute the packets addressed to the virtual IP address through one of the other active subnets.

The resilience against interface failures provided by virtual IP addresses depends on the fault resilience provided by the dynamic routing protocols, as well as on fault recovery features such as retransmissions built into the application logic.

5.2.2 Unlimited Mobility

Unlike physical IP addresses, which are limited in their mobility, virtual IP addresses are highly mobile. The degree of mobility is determined by the number of servers that an IP address on a specific server could be moved to. In other words, if you choose a physical IP address as an IP address of a network resource, you are limiting the set of potential servers to which this resource could be transparently failed over to.

If you choose a virtual IP address, the set of servers that the resource could be transparently moved to is potentially unlimited. This is because of the nature of virtual IP addresses; they are not bound to a physical wire and, as a result, they carry their virtual network to wherever they are moved. Again, there is an implicit assumption here that the location of a virtual IP address, wherever it be, is advertised to the owning server through some routing protocol. The ability to move an IP address across different machines becomes particularly important when it is required to transparently move or fail over a network resource that is identified by an IP address (which could be a shared volume or a mission-critical service) to another server on another network.

This unlimited mobility of virtual IP addresses is an advantage to network administrators, offering them more ease of manageability and greatly minimizing network reorganization overhead. For network administrators, shuffling services between different IP networks is the rule rather than the exception. The need often arises to move a machine hosting a particular service to some other IP network, or to move a service hosted on a particular machine to be rehosted on some other machine connected to a different IP network. If the service is hosted on a physical IP address, accommodating these changes involves rehosting the service on a different IP address pulled out from the new network, and appropriately changing the DNS entry for the service to point to the new IP address. However, if the service is hosted on a virtual IP address, the necessity of changing the DNS entries for the service is eliminated.

5.3 Other Added Features

- ♦ [Section 5.3.1, “Support for Host Mask,” on page 81](#)
- ♦ [Section 5.3.2, “Source Address Selection for Outbound Connections,” on page 81](#)

5.3.1 Support for Host Mask

Virtual boards support configuring virtual IP addresses with a host mask. This results in a single address being used rather than an entire subnet. See [Section 5.4, “Reducing the Consumption of Additional IP Addresses,” on page 82](#).

5.3.2 Source Address Selection for Outbound Connections

Full resilience of connections to interface failures can be ensured only when the connections are established between machines through using virtual IP addresses as end point addresses. This means an application that initiates outbound connections to a virtual IP address should also preferably use a virtual IP address as its local end point address.

This isn't difficult if the application binds its local socket end point address with a virtual IP address. However, there are some legacy applications that bind their sockets to a wildcard address (such as 0.0.0.0). When these applications initiate an outbound connection to other machines, TCP/IP chooses the outbound interface's IP address as the local socket end point address. In order for these legacy applications to take advantage of the fault resilience provided by the virtual IP address

feature, the default source address selection behavior of TCP/IP has been enhanced to accommodate the use of a virtual IP address as the source IP address. As a result, whenever a TCP or UDP application initiates an outbound connection with a wildcard source IP address, TCP/IP chooses the first bound virtual IP address as the source IP address for the connection.

This enhanced source address selection feature can be enabled or disabled globally as well as on a per-interface basis. This feature is enabled by default on all interfaces.

5.4 Reducing the Consumption of Additional IP Addresses

The only drawback in reaping the benefits of virtual IP addresses is the consumption of additional IP addresses. This constraint stems from the requirement that virtual IP network addresses must be different from all other real IP network addresses. Although this constraint is not particularly severe in enterprises that use private addressing (where the IP address space is potentially large), it could become limiting in organizations that do not use private addresses.

In enterprises that use fixed-length subnetting together with a dynamic routing protocol like RIP-1, each virtual IP address could consume a large number of host IP addresses. One way to circumvent this problem is to configure a virtual IP address with a host mask of all 1s (that is, FF.FF.FF.FF), thereby consuming only one host IP address. Of course, the viability of this option depends on the ability of the RIP-1 routers on the network to recognize and honor the advertised host routes.

In autonomous systems that use variable-length subnet masking (VLSM) together with routing protocols like RIP-II or OSPF, the consumption of additional IP addresses is not a major problem. You could simply configure a virtual IP address with an IP network mask as large as possible (including a host mask of all 1s), thereby limiting the number of addresses consumed by the virtual IP address space.

In any network environment, one of the first obstacles is how clients locate and connect to the services. A business continuity cluster can exacerbate this problem because services can migrate to nodes on a completely different network segment. Although there are many potential solutions to this problem, such as DNS and SLP, none of them offers the simplicity and elegance of virtual IP addresses. With virtual IP addresses, the IP address of the service can follow the service from node to node in a single cluster, as well as from node to node in separate, distinct clusters. This makes the client reconnection problem trivial; the client just waits for the new route information to be propagated to the routers on the network. No manual steps are required, such as modifying a DNS server.

To use a virtual IP address in a business continuity cluster, we recommend using a host mask. To understand why, consider the fact that each service in a clustered environment must have its own unique IP address or, a unique virtual IP address. Furthermore, consider that each virtual IP address belongs to a virtual IP network whose route is being advertised by a single node within a cluster. Because Novell Cluster Services can migrate a service and its virtual IP address from one node to another, the virtual IP network must migrate to the same node as the service. If multiple virtual IP addresses belong to a given virtual IP network, one of two events must occur:

- ◆ All services associated with the virtual IP addresses on a given virtual IP network must fail over together.
- ◆ The virtual IP addresses on a given virtual IP network must go unused, thereby wasting a portion of the available address space.

Neither of these situations is desirable. Fortunately, the use of host masks remedies both.

5.5 Configuring Virtual IP Addresses

The routers in a virtual IP address configuration must be running the RIP I or RIP II protocols. For a business continuity cluster, RIP II is the preferred protocol and should be used whenever possible. In NetWare, this can be accomplished by configuring the NetWare RIP Bind Options to use RIP I and RIP II, or RIP II only. Also, the command `SET RIP2 AGGREGATION OVERRIDE=ON` must be added to the `autoexec.ncf` file of any NetWare routers in this configuration.

After the appropriate virtual IP addresses and host masks have been determined, you can enable virtual IP addresses in a business continuity cluster by using the following process:

1. The `autoexec.ncf` file on each node in both clusters must be modified to add the following two lines. The first line loads the virtual driver and creates a virtual board named VNIC. The second line disables RIP 2 route aggregation on the cluster nodes.

```
LOAD VNIC NAME=VNIC
```

```
SET RIP2 AGGREGATION OVERRIDE=ON
```

2. The command to bind a virtual IP address for the service must be added to the cluster resource load script.

The following is an example of a cluster resource load script for a standard NetWare volume called Homes. This example uses host masks and assumes the virtual board has been named VNIC. Notice that the command to add a secondary IP address has been replaced with the `BIND IP VNIC Mask=255.255.255.255 Address=10.1.1.1` command, which binds the virtual IP address 10.1.1.1 to the virtual board.

```
nss /poolactivate=HOMES
```

```
mount HOMES VOLID=254
```

```
CLUSTER CVSBIND ADD BCC_HOMES_SERVER 10.1.1.1
```

```
NUDP ADD BCC_HOMES_SERVER 10.1.1.1
```

```
BIND IP VNIC Mask=255.255.255.255 Address=10.1.1.1
```

3. The command to unbind the virtual IP address must be added to the cluster resource unload script.

The following is the matching cluster resource unload script for the same NetWare volume discussed above. Notice the command to delete the secondary IP address has been replaced with the `UNBIND IP VNIC Address=10.1.1.1` command, which unbinds the virtual IP address 10.1.1.1 from the virtual board.

```
UNBIND IP VNIC Address=10.1.1.1
```

```
CLUSTER CVSBIND DEL BCC_HOMES_SERVER 10.1.1.1
```

```
NUDP DEL BCC_HOMES_SERVER 10.1.1.1
```

```
nss /pooldeactivate=HOMES /overridetype=question
```

4. If the cluster resource is a clustered-enabled pool or volume, the IP address of that resource needs to be changed to the virtual IP address. You can do this using ConsoleOne®, Novell Remote Manager, or iManager. This change is not needed for any non-volume cluster resources like DHCP.

5.5.1 Displaying Bound Virtual IP Addresses

To verify that a virtual IP address is bound, enter `display secondary ipaddress` at the server console of the cluster server where the virtual IP address is assigned. This displays all bound virtual IP addresses. A maximum of 256 virtual IP addresses can be bound.

Implementing a Multiple-Tree BCC

A

Although the information contained in the other sections of this document describes an eDirectory™ single-tree BCC implementation, most of it is also useful for configuring and managing BCC in a multiple-tree environment. This section contains additional instructions and information for multiple-tree BCC implementations.

- ♦ [Section A.1, “Using Identity Manager to Copy User Objects to Another eDirectory Tree,” on page 85](#)
- ♦ [Section A.2, “Configuring User Object Synchronization,” on page 85](#)
- ♦ [Section A.3, “Creating SSL Certificates,” on page 86](#)
- ♦ [Section A.4, “Synchronizing the BCC-specific Identity Manager Drivers,” on page 87](#)
- ♦ [Section A.5, “Preventing Identity Manager Synchronization Loops,” on page 87](#)
- ♦ [Section A.6, “Migrating Resources to Another Cluster,” on page 89](#)

A.1 Using Identity Manager to Copy User Objects to Another eDirectory Tree

The procedures explained in this section are normally performed after completing [“Installing and Configuring Identity Manager” on page 20](#).

The Identity Manager eDirectory driver has a synchronization feature that copies objects that exist in one tree to another tree where they don't exist. For business continuity clusters, this feature can be used to copy User objects from one cluster to another cluster in a separate eDirectory tree. For example, if you have one tree that has 10,000 users and a second new tree that does not yet have users defined, you can use Identity Manager to quickly copy the 10,000 users to the new tree.

For more information on copying User objects by using Identity Manager, see [“Migrating or Copying User Objects” \(http://www.novell.com/documentation/idmdrivers/index.html?page=/documentation/idmdrivers/edirectory/data/brj81j4.html\)](#) in the *Identity Manager Driver for eDirectory Implementation Guide*.

A.2 Configuring User Object Synchronization

If the clusters in your business continuity cluster are in separate eDirectory trees and you require user-based access control, then User object synchronization is required.

To configure the Identity Manager driver for User object synchronization:

- 1 Start your Internet browser and enter the URL for iManager.
The URL is `http://server_ip_address/nps/iManager.html`. Replace *server_ip_address* with the IP address or DNS name of the server that has iManager and the Identity Manager preconfigured templates for iManager installed.
- 2 Specify your username and password, specify the tree where you want to log in, then click *Login*.
- 3 In the left column, click *DirXML Utilities*, then click the *New Driver* link.

- 4 Choose to either place the new driver in a new driver set, or add the driver to the driver set you created for cluster resource synchronization, then click *Next*.
Both the User Object Synchronization driver and the Cluster Resource Synchronization driver can be added to the same driver set.
- 5 Specify the driver set name, context, and the server that the driver set will be associated with.
The server is the same server where you installed the Identity Manager engine and eDirectory driver.
- 6 Choose to *not* create a new partition for the driver set, then click *Next*.
- 7 Choose to import a preconfigured driver from the server, select the Identity Manager preconfigured template for User object synchronization, then click *Next*.
The template name is `BCCUserObjectSynchronization.XML`.
- 8 Fill in the values on the wizard page as prompted, then click *Next*.
Each field contains an example of the type of information that should go into the field. Descriptions of the information required are also included with each field.
Additional information for the wizard page fields can be found in “[Importing the Sample Driver Configuration](http://www.novell.com/documentation/dirxml/drivers/edirectory/data/bozobjif.html)” (<http://www.novell.com/documentation/dirxml/drivers/edirectory/data/bozobjif.html>) in the *DirXML Driver for eDirectory Implementation Guide*.
- 9 In the left column of the iManager page, click *DirXML*, then click *DirXML Overview*.
- 10 Search the eDirectory tree for the Identity Manager driver sets by clicking *Search*.
- 11 Click the *User Sync* driver icon, then click *Migrate from eDirectory*.
- 12 Click *Add*, browse to and select the context that contains the User objects, then click *OK*.
- 13 (Optional) Exclude the Admin User object from being synchronized:
 - 13a Click the *Exclude Administrative Roles* button, then click *Add*.
 - 13b Browse to and select the Admin User object, then click *OK*.
- 14 Perform [Step 1](#) through [Step 13](#) for each cluster that is in a separate tree.

A.3 Creating SSL Certificates

In a multiple-tree BCC, you must create an SSL certificate for the Cluster Resource Synchronization Driver, and an SSL certificate for the User Object Synchronization driver. Creating one certificate creates that certificate for a driver pair. For example, creating an SSL certificate for the Cluster Resource Synchronization driver creates the certificate for the Cluster Resource Synchronization drivers on both clusters.

To create an SSL certificate:

- 1 Start your Internet browser and enter the URL for iManager.
The URL is `http://server_ip_address/nps/iManager.html`. Replace *server_ip_address* with the IP address or DNS name of the server that has iManager and the Identity Manager preconfigured templates for iManager installed.
- 2 Specify your username and password, specify the tree where you want to log in, then click *Login*.
- 3 In the left column, click *DirXML Utilities*, then click *NDS-to-NDS Driver Certificates*.
- 4 Specify the requested driver information for both eDirectory trees.

You must specify the driver name (including the context) you supplied in [Step 8 on page 34](#) for the current tree. Use the following format when specifying the driver name:

DriverName.DriverSet.OrganizationalUnit.OrganizationName

Ensure that there are no spaces (beginning or end) in the specified context, and do not use the following format:

cn=DriverName.ou=OrganizationalUnitName.o=OrganizationName

A.4 Synchronizing the BCC-specific Identity Manager Drivers

After creating the BCC-specific Identity Manager drivers and SSL certificates, if you are adding a new cluster to an existing business continuity cluster in a multiple-tree BCC, you must synchronize the BCC-specific Identity Manager drivers for the Cluster and User objects. If the BCC-specific Identity Manager drivers are not synchronized, clusters cannot be enabled for business continuity. This is not necessary unless you are adding a new cluster to an existing business continuity cluster.

To synchronize the BCC-specific Identity Manager drivers:

- 1 Start your Internet browser and enter the URL for iManager.
The URL is `http://server_ip_address/nps/iManager.html`. Replace *server_ip_address* with the IP address or DNS name of the server that has iManager and the Identity Manager preconfigured templates for iManager installed.
- 2 Specify your username and password, specify the tree where you want to log in, then click *Login*.
- 3 In the left column, click *DirXML*, then click the *DirXMLOverview* link.
- 4 Search for and find the BCC driver set.
- 5 Click the red *Cluster Sync* icon for the driver you want to sync, then click the *Migrate from eDirectory* button.
- 6 Click *Add*, browse to and select the Cluster object for the new cluster you are adding, then click *OK*.
Selecting the Cluster object causes the BCC-specific Identity Manager drivers to synchronize.
- 7 If you chose to include User object synchronization, repeat the above steps, and in [Step 5](#), click the *User Sync* icon.

A.5 Preventing Identity Manager Synchronization Loops

If you have three or more clusters each in separate eDirectory trees in your business continuity cluster, you should set up IDM User object and Cluster Resource object synchronization in a manner that prevents Identity Manager synchronization loops. Identity Manager synchronization loops can cause excessive network traffic and slow server communication and performance.

For example, in a three-cluster business continuity cluster, an Identity Manager synchronization loop occurs when Cluster One is configured to synchronize with Cluster Two, Cluster Two is configured to synchronize with Cluster Three, and Cluster Three is configured to synchronize back to Cluster One. This is illustrated in [Figure 2-3](#).

Figure A-1 Three-Cluster Identity Manager Synchronization Loop

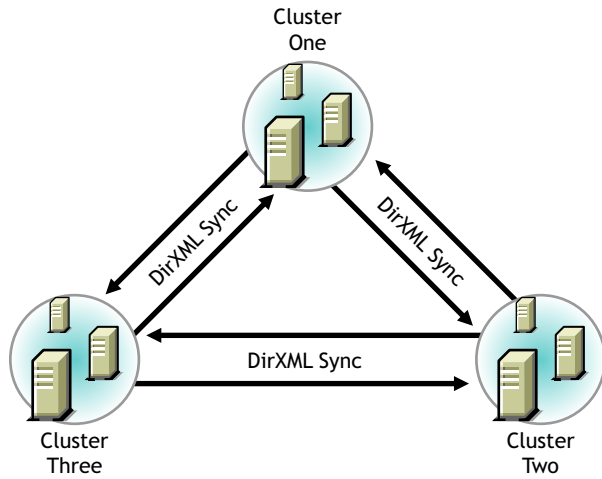

A preferred method is to make Cluster One an Identity Manager synchronization master in which Cluster One synchronizes with Cluster Two, and Cluster Two and Cluster Three both synchronize with Cluster One. This is illustrated in [Figure 2-4](#).

Figure A-2 Three-Cluster Identity Manager Synchronization Master

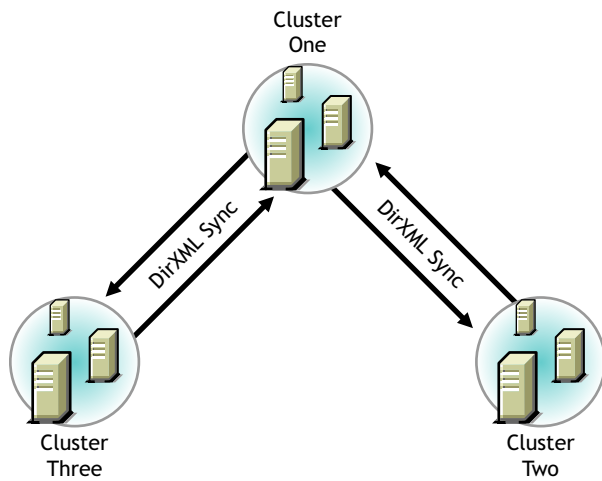

You could also have Cluster One synchronize with Cluster Two, Cluster Two synchronize with Cluster Three, and Cluster Three synchronize back to Cluster Two as illustrated in [Figure 2-5](#).

Figure A-3 Alternate Three-Cluster Identity Manager Synchronization Scenario

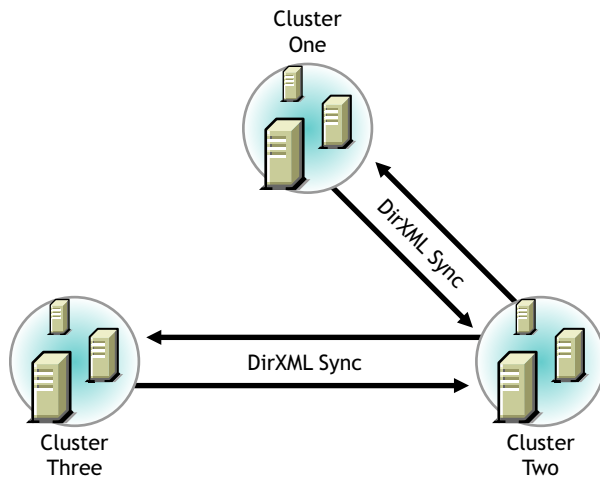

To change your BCC synchronization scenario:

- 1 In the Connections section of the Business Continuity Cluster Properties page, select one or more peer clusters that you want a cluster to synchronize to, then click *Edit*.

In order for a cluster to appear in the list of possible peer clusters, that cluster must have the following:

- ◆ Business Continuity Clustering software installed.
- ◆ Identity Manager installed.
- ◆ BCC Identity Manager drivers configured and running.
- ◆ Be enabled for business continuity.

A.6 Migrating Resources to Another Cluster

IMPORTANT: If you are migrating a pool to a cluster in another tree and you want to maintain that pool's volume trustee assignments, you must migrate the pool to a server with an eDirectory replica. The replica must be at least read-only and must contain all users. After migrating the pool to a server with an eDirectory replica, enter the following console command on that server for each volume in the pool:

```
NSS/ResetObjectIDStore=volumentname
```

This command updates all volume trustee assignments and should be run at night, on a weekend, or during a period of low network utilization. Trustee assignments become effective immediately, but might take a few hours to display correctly in management utilities.

If you migrate the pool to a server in another tree without an eDirectory replica, you must, within 90 days, migrate that pool to a server with an eDirectory replica and then run the command for each volume.

Setting Up Auto-Failover

B

Auto-Failover is available beginning in Business Continuity Clustering 1.1. To set up the auto-failover feature, you must enable it, then configure the auto-failover settings.

WARNING: Auto-Failover is disabled by default and is not recommended. It should only be enabled after a thorough examination and review of your network and geographic site infrastructure. You should seriously consider the adverse conditions that might occur as a result of enabling this feature.

These conditions may include but are not limited to:

- ♦ Data loss at one or more geographic sites
- ♦ Data corruption at one or more geographic sites
- ♦ Data divergence at one or more geographic sites

For example, if there is a loss of communication between two clusters and auto-failover has been enabled and configured, each cluster will assert ownership of BCC-enabled cluster resources. These resources then automatically load on both clusters.

When communication between cluster has been restored, some of the data on each cluster is different. This is called data divergence. Also, the mirroring or synchronization process either fails, or attempts to overwrite any changed data on one cluster. This causes either data loss or data corruption.

-
- ♦ [Section B.1, “Enabling Auto-Failover,” on page 91](#)
 - ♦ [Section B.2, “Creating an Auto-Failover Policy,” on page 92](#)
 - ♦ [Section B.3, “Refining the Auto-Failover Policy,” on page 92](#)
 - ♦ [Section B.4, “Adding or Editing Monitor Configurations,” on page 93](#)

B.1 Enabling Auto-Failover

To enable auto-failover for all Business Continuity Cluster resources in a cluster:

- 1 Start your Internet browser and enter the URL for iManager.
The URL is `http://server_ip_address/nps/iManager.html`. Replace *server_ip_address* with the IP address or DNS name of the server that has iManager and the Identity Manager preconfigured templates for iManager installed.
- 2 Specify your username and password, specify the tree where you want to log in, then click *Login*.
- 3 In the left column, click *Clusters*, then click the *Cluster Options* link.
- 4 Specify a cluster name, or browse and select one.
- 5 Click the *Properties* button and then click the *Business Continuity* tab.
- 6 Click the *Auto-Failover* link just under the tabs.
- 7 Select the *Enable Automatic Failover of Business Continuity Cluster Resources* check box, then click *Apply*.

- 8 Continue with [Section B.2, “Creating an Auto-Failover Policy,”](#) on page 92 to create a failover policy.

Auto-failover is not completely enabled until you create a failover policy.

B.2 Creating an Auto-Failover Policy

By default, no auto-failover policy exists for BCC. You must create an auto-failover policy for each cluster in your BCC where you want auto-failover enabled. This is required to automatically fail over resources from one cluster to another.

- 1 In iManager, under *Cluster Membership Monitoring Settings*, select a cluster and click the *Edit* link.
- 2 Under *Membership Threshold*, select the *Enable* check box, select either *Percent Fail* or *Nodes Fail*, and specify either the percentage of failed nodes or the number of failed nodes.
The node failure number or percentage you specify must be met for the selected cluster before resources automatically fail over to another cluster.
- 3 Under *Communication Timeout*, select the *Enable* check box and specify the number of minutes that must elapse without any communication between clusters before resources automatically fail over to another cluster.
- 4 Click *OK* to finish editing the policy.
- 5 Click the *Apply* button to save your settings.

B.3 Refining the Auto-Failover Policy

You can further refine auto-failover policies to give you more control over if or when an auto-failover occurs. To do this, click the *Advanced* button to display additional fields for specifying auto-failover criteria and adding monitoring information.

The policy for automatic failover is configured by creating rules. Each row in the Failover Policy Configuration table represents a rule that applies to a single cluster, or to all clusters in the BCC. Each rule contains a set of conditions. Each condition tests one of the following criteria:

- ♦ The value of an indication reported by a monitor
- ♦ The amount of time the connection to a cluster has been down
- ♦ If the connection to a cluster is up

These conditions can be combined in any order to construct a more robust rule that helps to avoid an undesired failover. For failover to occur, each condition of only one rule must be satisfied for the specified cluster or clusters.

For example, a rule might contain only one condition that tests whether a connection to a specific cluster has been down for five or more minutes. Failover occurs when peer clusters agree that the connection to the cluster specified in the rule has been down for five or more minutes. If the peer clusters do not agree about the connection being down (that is, one cluster has a valid connection to the specified cluster), failover does not occur. More complex rules can be constructed that contain multiple conditions.

If previously configured, the fields under *Failover Policy Configuration* should already contain information on the policies that were created in the *Cluster Membership Monitoring Settings* section of the page.

- 1 Under *Failover Policy Configuration*, select a policy and click *Edit* to further refine a rule. Click *Delete* to remove the rule, or click *New* to create a new rule that you can add the additional failover conditions to.
- 2 Select the cluster that you want the rule to apply to, or select *All* to apply the policy to all clusters.
- 3 Under *Conditions*, choose the type of condition and the appropriate values. To add multiple conditions to the rule, click the *Add* button below the condition.

You can use the default setting of *Monitor* if you don't want to apply the cluster up or cluster down criteria to this policy. You can also specify or change the percent or number of nodes criteria that are used to determine if an auto failover can occur.
- 4 Click *Apply* to save your settings.

For rules with monitor conditions automatically created by using the Cluster Membership Monitoring Settings table, you can add a condition that tests if the connection to the peer cluster is up. Adding this condition changes the behavior of the rule. With this rule, a graceful automatic failover of resources can happen when the connection to the peer cluster is up.

You can also specify or change the criteria for percent or number of nodes that are used to determine if an automatic failover can occur. Do not however use a membership condition of total node failure (either one-hundred percent or the total number of nodes); the condition can't be satisfied, because the cluster won't be up to report this state. Also, adding a connection down condition to a rule with a condition that tests cluster membership is not recommended. It is highly unlikely that cluster membership information for a specific cluster will be reported to peer clusters when the connection to that specific cluster is down. For these reasons, you should create a separate rule with a connection down condition.

B.4 Adding or Editing Monitor Configurations

Clicking the *Advanced* button also displays an additional section on this page called *Health Monitor Configuration*. Monitors are an important part of the automatic failover feature, and are separate processes that perform a specialized task to analyze the health of a specific cluster or all clusters in the BCC. These monitors report an indication of health to BCC. BCC in turn uses the reported information to analyze the failover policy to determine if resources should be migrated from a specific cluster. Business Continuity Clustering 1.1 ships with two monitors (nodecnt and nodepnt) that report an indication of health that represents either the percentage or number of nodes that are not a member of a specific cluster.

If they are configured by using the Cluster Membership Monitoring Settings table, the fields under *Health Monitor Configuration* should already contain information for the health monitor (nodepnt or nodecnt) included with Business Continuity Clustering 1.1. Although default values have already been set, you can customize some of the monitor settings for the cluster membership monitors. If you have created your own custom monitor, you can click *New* to add configuration settings to your monitor.

- 1 In iManager, under *Monitor Name* in the *Health Monitor Configuration* section, select a monitor and click *Edit*.
- 2 Under *Clusters*, select the cluster or clusters that you want this monitor to apply to.

3 Specify the maximum health indication that the monitor will report.

This value is used when creating a failover policy to validate the rules. This is the maximum value that can be used for the threshold type when you create a failover policy. For example, if you specified percent fail membership monitoring, the maximum values would be 100 (for 100 percent) for the nodepnt monitor. If you specified nodes fail membership monitoring, the maximum value for the nodecnt monitor is the maximum number of nodes permitted in a cluster, which is 32. If you created your own custom monitor, the values could be different.

For the nodepnt and nodecnt monitors, the *Maximum Health Indication* value is for information only, and should not be changed.

4 Under *Short Polling Interval*, specify the number of seconds the monitor will wait each time it contacts the cluster or clusters to get health information.

The *Long Polling Interval* is not used with the default nodepnt and nodecnt monitors. This value might be used for some custom monitors.

5 Specify which platforms (Linux or NetWare[®]) you want to be monitored by the health monitor and whether you want the monitor enabled for the selected clusters.

The *Optional Parameter* field specifies a monitor-specific string value that is passed to the monitor as a startup parameter.

The nodepnt and nodecnt monitors do not support optional parameters.

6 Click *Apply* to save your settings.

NOTE: See the [BCC NDK documentation \(http://developer.novell.com/documentation/cluster/index.html?page=/documentation/cluster/ncss_enu/data/bktitle.html\)](http://developer.novell.com/documentation/cluster/index.html?page=/documentation/cluster/ncss_enu/data/bktitle.html) for more information on creating custom failover policies.

Security Considerations

C

This section contains specific instructions on how to configure and maintain a business continuity cluster in the most secure way possible. It contains the following subsections:

- ♦ [Section C.1, “Security Features,” on page 95](#)
- ♦ [Section C.2, “Security Configuration,” on page 95](#)
- ♦ [Section C.3, “Other Security Considerations,” on page 100](#)

C.1 Security Features

The following table contains a summary of the security features of Business Continuity Clustering 1.1:

Table C-1 Business Continuity Clustering 1.1 Security Features

Feature	Yes/No	Details
Users are authenticated	Yes	Administrative users are authenticated via eDirectory™.
Users are authorized	Yes	Users are authorized via eDirectory trustees.
Access to configuration information is controlled	Yes	Access to the administrative interface is restricted to valid users that have write rights to the configuration files.
Roles are used to control access	Yes	Configurable through iManager.
Logging and/or security auditing is done	Yes	Syslog on Linux. Fake syslog on NetWare.
Data on the wire is encrypted by default	Yes	The following data is encrypted on the wire: <ul style="list-style-type: none">♦ Inter-cluster communications♦ Identity Manager data can be encrypted
Data stored is encrypted	No	
Passwords, keys, and any other authentication materials are stored encrypted	Yes	Inter-cluster communications for usernames and passwords are encrypted. Cluster credentials are stored encrypted in eDirectory.
Security is on by default	Yes	

C.2 Security Configuration

The following subsections provide a summary of security-related configuration settings for Business Continuity Clustering 1.1:

- ♦ [Section C.2.1, “BCC Configuration Settings,” on page 96](#)
- ♦ [Section C.2.2, “Security Information for Other Products,” on page 99](#)

C.2.1 BCC Configuration Settings

The following table lists the BCC configuration settings that are security-related or impact the security of BCC:

Table C-2 BCC Security Configuration Settings

Configuration Setting	Possible Values	Default Value	Recommended Value for Best Security
Inter-cluster communications scheme	HTTP/HTTPS	HTTPS	HTTPS
Identity Manager communications	Secure/Non-secure		Secure
BCC Administrator user quota in <code>sys:tmp</code>	0 MB to unlimited MB	Unlimited MB	5 MB
BCC Administrator user	Any LUM-enabled eDirectory User		Unique BCC Administrator user (not Admin user)
BCC Administrator group	Any LUM-enabled eDirectory group	bccgroup	Unique group used for BCC administration
Peer cluster CIMOM URL	<code>http://cluster_ip_address</code> <code>https://cluster_ip_address</code>	<code>cluster_ip_address</code>	Default value

Changing the BCC XML Configuration

WARNING: You should not change these configuration settings unless instructed to do so by Novell Support. Doing so can have adverse affects on your cluster nodes and BCC.

The following XML is saved on the NCS:BCC Settings attribute on the local Cluster object in eDirectory. The BCC must be restarted for changes to these settings to take effect.

```
<bccSettings>
  <adminGroupName>bccgroup</adminGroupName>
  <authorizationCacheTTL>300</authorizationCacheTTL>
  <cimConnectTimeout>15</cimConnectTimeout>
  <cimReceiveTimeout>30</cimReceiveTimeout>
  <cimSendTimeout>30</cimSendTimeout>
  <idlePriorityThreshold>3</idlePriorityThreshold>
  <initialNormalThreads>3</initialNormalThreads>
  <initialPriorityThreads>2</initialPriorityThreads>
</bccSettings>
```



```

<ipcResponseTimeout>15</ipcResponseTimeout>
<maximumPriorityThreads>20</maximumPriorityThreads>
<minimumPriorityThreads>2</minimumPriorityThreads>
<resourceOfflineTimeout>300</resourceOfflineTimeout>
<resourceOnlineTimeout>300</resourceOnlineTimeout>
<scanForNewDevicesDelay>5</scanForNewDevicesDelay>
</bccSettings>

```

On Linux, the above XML is written to `/etc/opt/novell/bcc/bccsettings.xml`. It should be noted that on Linux this file might be overwritten by BCC at any time. Therefore, any changes to this file on Linux are ignored and lost. All changes should be made in eDirectory.

[Table C-3](#) provides additional information on each setting:

Table C-3 BCC XML Settings

Setting	Description	Default Value
<adminGroupName>	The name of the LUM-enabled group that BCC uses on Linux.	bccgroup
<authorizationCacheTTL>	The number of seconds the authorization rights are cached in the BCC OpenWBEM provider.	300 seconds This is not supported until the first support pack.
<cimConnectTimeout>	BCC CIM client connect timeout in seconds.	15 seconds
<cimReceiveTimeout>	BCC CIM client receive timeout in seconds.	30 seconds
<cimSendTimeout>	BCC CIM client send timeout in seconds.	30 seconds
<idlePriorityThreshold>	The number of idle high priority threads before BCC starts killing priority threads.	3
<initialNormalThreads>	The number of normal threads created by BCC.	3
<initialPriorityThreads>	The number of high priority threads created by BCC at startup.	2
<ipcResponseTimeout>	The timeout in seconds that BCC waits for an IPC response.	15
<maximumPriorityThreads>	The maximum number of high priority threads BCC creates.	20
<minimumPriorityThreads>	The minimum number of high priority threads BCC keeps after killing idle high priority threads.	2
<resourceOfflineTimeout>	The number of seconds BCC waits for a resource to go offline during a BCC migrate.	300

Setting	Description	Default Value
<resourceOnlineTimeout>	The number of seconds BCC waits for a resource to go online during a BCC migrate.	300
<scanForNewDevicesDelay>	The number of seconds BCC sleeps after performing a scan for new devices during a BCC migration of a resource.	5

Disabling SSL for Inter-Cluster Communication

Disabling SSL for inter-cluster communication should only be done for debugging purposes, and should not be done in a production environment or for an extended period of time.

To turn off SSL for inter-cluster communication, or to specify a different communication port, you need to modify the Novell Cluster Services™ Cluster object that is stored in eDirectory by using an eDirectory management tool such as iManager or ConsoleOne®. See the [Novell iManager 2.5 Documentation Web site \(http://www.novell.com/documentation/imanager25/\)](http://www.novell.com/documentation/imanager25/) for information on using iManager.

Disabling SSL communication to a specific peer cluster requires changing the BCC management address to the peer cluster. The address is contained in the NCS:BCC Peers attribute that is stored on the NCS Cluster object.

For example, a default NCS:BCC Peers attribute could appear similar to the following example:

```
<peer>
  <cluster>chicago_cluster</cluster>
  <tree>DIGITALAIRLINES-TREE</tree>
  <address>10.1.1.10</address>
</peer>
```

To disable SSL for inter-cluster communication, you would change the <address> attribute to specify http:// with the IP address, as shown in the following example:

```
<peer>
  <cluster>chicago_cluster</cluster>
  <tree>DIGITALAIRLINES-TREE</tree>
  <address>http://10.1.1.10</address>
</peer>
```

The BCC management address of `chicago_cluster` now specifies non-secure HTTP communication.

The BCC management port can also be changed by modifying the NCS:BCC Peers attribute values.

The default ports for secure and non-secure inter-cluster communication are 5989 and 5988 respectively.

For example, if you want to change the secure port on which OpenWBEM listens from port 5989 to port 1234, you would change the <address> attribute value in the above examples to:

```

<peer>
  <cluster>chicago_cluster</cluster>
  <tree>DIGITALAIRLINES-TREE</tree>
  <address>10.1.1.10:1234</address>
</peer>

```

The attribute now specifies that inter-cluster communication uses HTTPS over port number 1234.

The NCS:BCC Peers attribute has a value for each peer cluster in the BCC. Attribute values are synchronized among peer cluster by the BCC-specific Identity Manager driver, so a change to an attribute value on one cluster causes that attribute value to be synchronized to each peer cluster in the BCC.

The changes do not take effect until either a reboot of each cluster node, or by a restart of the Business Continuity Clustering software on each cluster node.

The following table provides an example of possible combinations of scheme and port specifier for the <address> tag for values of the NCS:BCC Peers attribute:

Table C-4 Example of Scheme and Port Specifier Values for the NCS:BCC Peers Attribute

Value	Protocol Used	Port Used
10.1.1.10	HTTPS	5989
10.1.1.10:1234	HTTPS	1234
http://10.1.1.10	HTTP	5988
http://10.1.1.10:1234	HTTP	1234
https://10.1.1.10	HTTPS	5989
https://10.1.1.10:1234	HTTPS	1234

C.2.2 Security Information for Other Products

The following table provides links to security-related information for other products that impact the security of BCC:

Table C-5 Security Information for Other Products

Product Name	Links to Security Information
NSS	"Securing Access to NSS Volumes, Directories, and Files" (http://www.novell.com/documentation/oes/nss_enu/data/bv8n39l.html#bv8n39l) . and "Security Considerations" (http://www.novell.com/documentation/oes/nss_enu/data/bx8gp06.html) .

Product Name	Links to Security Information
eDirectory	Security for eDirectory is provided by NICI. See the <i>NICI 2.7x Administration Guide</i> (http://www.novell.com/documentation/nici27x/nici_admin_guide/data/a20gkue.html)
Identity Manager (IDM)	"Security: Best Practices" (http://www.novell.com/documentation/idm/admin/data/b1bsw73.html) in the <i>Identity Manager Administration Guide</i> .
iSCSI	"Configuring Access Control to iSCSI Targets" (http://www.novell.com/documentation/iscsi1_nak/iscsi/data/h2mdblj1.html) and "Enabling and Configuring iSCSI Initiator Security" (http://www.novell.com/documentation/iscsi1_nak/iscsi/data/hclny85e.html) in the <i>iSCSI 1.1.3 Administration Guide for NetWare 6.5</i> .
OpenWBEM	OpenWBEM should be configured on each node to allow only the necessary users. OpenWBEM by default allows all users. For more information, see "Changing the Authentication Method" (http://www.novell.com/documentation/oes/cimom/data/bv4xqz9.html) in the <i>OpenWBEM Services Administration Guide for OES</i> .
Linux User Management (LUM)	<i>Linux User Management Technology Guide</i> (http://www.novell.com/documentation/oes/lumadgd/data/bookinfo.html#bookinfo).

C.3 Other Security Considerations

- ◆ Servers should be kept in a physically secure location with access by authorized personnel only.
- ◆ The corporate network should be physically secured against eavesdropping or packet sniffing. Any packets associated with the administration of BCC should be the most secured.
- ◆ Access to BCC configuration settings and logs should be restricted. This includes file system access rights, FTP access, access via Web utilities, SSH, and any other type of access to these files.
- ◆ Services that are used to send BCC data to other servers or e-mail accounts or that protect BCC data should be examined periodically to ensure that they have not been tampered with.
- ◆ When synchronizing cluster or user information between servers outside the corporate firewall, the HTTPS protocol should be employed. Because resource script information is passed between clusters, strong security precautions should be taken.
- ◆ When a BCC is administered by users outside of the corporate firewall, the HTTPS protocol should be used. A VPN should also be employed.
- ◆ If a server is accessible from outside the corporate network, a local server firewall should be employed to prevent direct access by a would-be intruder.
- ◆ Audit logs should be kept and analyzed periodically.

Documentation Updates

D

This section contains information about documentation content changes made to the *Novell® Business Continuity Clustering 1.1 for NetWare Administration Guide* since the 1.1 release. If you are an existing user, review the change entries to readily identify modified content. If you are a new user, simply read the guide in its current state.

Refer to the publication date, which appears on the title page, to determine the release date of this guide. For the most recent version of the *Novell Business Continuity Clustering 1.1 for NetWare Administration Guide*, see the [Business Continuity Clustering Documentation Web site \(http://www.novell.com/documentation/bcc/index.html\)](http://www.novell.com/documentation/bcc/index.html).

In this section, content changes appear in reverse chronological order, according to the publication date. Within a dated entry, changes are grouped and sequenced alphabetically. Each change entry provides a link to the related topic and a brief description of the change.

This document was updated on the following dates:

- ♦ [Section D.1, “April 30, 2008,” on page 101](#)
- ♦ [Section D.2, “February 15, 2008,” on page 102](#)

D.1 April 30, 2008

Updates were made to the following sections. The changes are explained below.

- ♦ [Section D.1.1, “Setting Up Novell Business Continuity Clustering Software,” on page 101](#)

D.1.1 Setting Up Novell Business Continuity Clustering Software

Location	Change
Section 2.2.3, “Configuring a BCC Administrator User,” on page 24	This section is new.
Section 2.4.3, “Configuring Cluster Resources for Business Continuity,” on page 43	You cannot set the BCC attributes for a cluster resource until after the resource is created.

D.2 February 15, 2008

Updates were made to the following sections. The changes are explained below.

- ♦ [Section D.2.1, “Installation and Setup,” on page 102](#)
- ♦ [Section D.2.2, “Troubleshooting Business Continuity Clustering 1.1,” on page 102](#)

D.2.1 Installation and Setup

Location	Change
Section 2.1, “Requirements,” on page 17	Added requirements for BASH and changes in the <code>autoexec.ncf</code> file.
“Installing and Configuring Identity Manager” on page 20	The NCP™ server objects for the virtual server of a BCC enabled resource are also placed in the landing zone.
Section 2.4.1, “Configuring Identity Manager Drivers for the Business Continuity Cluster,” on page 33	The NCP server objects for the virtual server of a BCC enabled resource are also placed in the landing zone.
Section 2.5, “Managing a Novell Business Continuity Cluster,” on page 46	The definition for the <code>cluster enable</code> command was updated.

D.2.2 Troubleshooting Business Continuity Clustering 1.1

Location	Change
Section 4.4, “Security Equivalent User,” on page 64	The NCP server objects for the virtual server of a BCC enabled resource are also placed in the landing zone.